



Blue Ribbon Service

GSS-1349

International[®]
Cub[®] Cadet Tractor

CHASSIS
Model 70 and 100

Price 75¢

INTERNATIONAL HARVESTER COMPANY
180 NORTH MICHIGAN AVE. CHICAGO 1, ILLINOIS

FOREWORD

The instructions and special tools shown in this Blue Ribbon Service Manual are for use by International Harvester Dealers and their factory trained servicemen.

The specifications as listed in this manual are current as of the printing date. Due to changes and improvements in our products, dealers are periodically issued service bulletins to keep this manual up-to-date. We suggest you refer to the most recent information when performing service work on this equipment.

International Harvester Factory Trained servicemen are best qualified to service I.H. equipment.

INTRODUCTION

This manual covers the servicing procedures of the chassis components of the Models 70 and 100 International Cub Cadet tractors. The engine, fuel system and ignition system are covered in Blue Ribbon Service Manual GSS-1350 (also the electrical system when so equipped).

LIBRARY FILING INFORMATION

1. File this Manual in Book 12 after Divider Tab GSS-1349.
2. Enter the following information in the Service Manual Index.

Print, or preferably type in, the Manual Description, Form Number, and the Book Filed in, on the following pages:

Tractor Specifications	Page 3
Tractor Transmission	" 13
Tractor Differential & Final Drive	" 15
Tractor Clutch.	" 17
Tractor Brakes	" 19
Tractor Chassis	" 23

CONTENTS

	Page
Introduction	2
General Information	4
Clutch	5
Brake	5
Reduction Drive	6
Transmission	6
Differential	6
Rear Axles	6
Front Axle	6
Front Wheels	6
Steering	6
Creeper Attachment (Underdrive)	6
Specifications	8
Steering Assembly	10
Front Wheels and Bearings	12
Front Axle	13
Steering Knuckle Removal	13
Removal of Front Axle	13
Inspection and Repair	13
Reassembly of Front Axle	14
Reassembly of Steering Knuckles	14
Clutch	14
Brake	18
Splitting the Tractor	19
Reduction Drive	21
Rear Axles	23
Transmission and Differential	25
Removal and Disassembly (Differential)	25
Disassembly (Transmission)	26
Inspection and Repair	26
Reassembly	27
Creeper Drive	28

GENERAL INFORMATION



Illust. 1. Left front view of model 70 cadet.

The International Cub Cadet is available in two models. The model 70 is powered by a 7 horsepower, four cycle, air cooled, gasoline engine and is available with retractable hand starting or electric starting. The model 100 is powered by a 10 horsepower, four cycle, air cooled, gasoline engine and is available with electric starting only.

The chassis is the same for both models.

Tractors equipped with electric starting have a combination generator and cranking motor. Both models use the same generator-motor unit, however, the model 100 is equipped with a larger capacity battery.

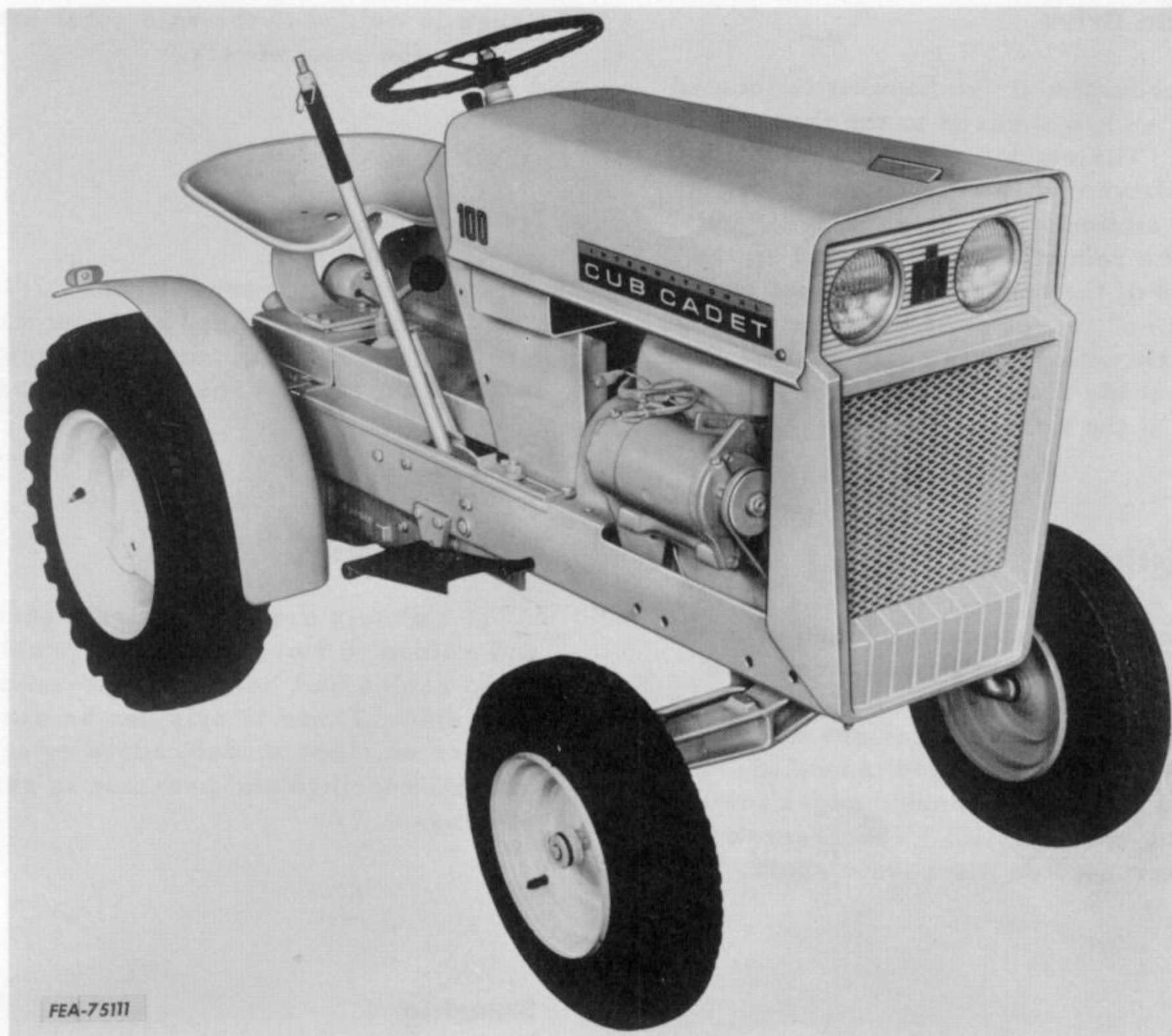

Illust. 2. Right front view of model 100 cadet.

The electrical systems of these tractors are automatically polarized when the starter button is pressed.

The clutch and brake are operated by a single foot pedal located on the left side of the tractor. Separate adjustments are provided for each unit.

All cadets are equipped with an implement control lever, conveniently located on the right side of the tractor.

Power is transferred directly to the clutch by a driving plate attached to the engine flywheel pulley.

Clutch

A friction disk, held between two spring loaded plates on the clutch shaft, transfers power through the clutch shaft to the gear reduction unit on standard tractors, and to the underdrive (creeper) unit on tractors so equipped.

Brake

Two friction material inserts apply "Caliper Type" holding to a round flat plate located on the splined front end of the transmission countershaft; thus, braking is applied through the differential to both rear wheels.

Reduction Drive

The reduction drive housing is located ahead of and is secured to the transmission housing. The reduction input shaft with gear is driven by the clutch shaft (or creeper attachment if so equipped), and drives the reduction gear located on the front end of the transmission input shaft. The ratio of reduction is seven to one. The input shaft with gear is supported by a ball bearing at the front and a needle roller bearing at the rear.

Transmission

Sliding spur gears are located on the transmission input shaft and mesh with spur gears on the countershaft. Shafts are mounted in ball, roller, and needle bearings. Gears have crowned induction hardened teeth with rounded edges for ease of shifting and long life. The reverse idler gear is mounted on a separate shaft.

Differential

Two pinions, a pinion shaft and two side gears are positioned in the one piece cast iron carrier case. The gears are carburized, hardened alloy steel.

The bevel gear is riveted to the carrier case. The carrier assembly is mounted in tapered roller bearings. Bearings are pre-loaded to control deflection of the assembly when loaded.

Rear Axles

The rear axles are splined on their inner end where they are supported and driven by the differential side gears. Snap rings secure the axle shafts in the side gears. A bronze bushing in each axle carrier supports the rear axle outer end. A

flange is welded to the axle outer end to receive the rear wheels.

Front Axle

The cast iron front axle has "I" beam construction with raised arch center section. The axle is supported by a pivot shaft in the main frame cross channel bracket.

Front Wheels

The wheels are formed from sheet steel and welded to steel tubing. A pre-lubricated sealed ball bearing is pressed into each side. These wheels can be used for service on older model cadets by removing the ball bearings and pressing in service bushings.

Steering

A spiral worm cam and lever with single follower and control arm actuates the ball socket drag link to the left front steering knuckle. The ball socket tie rod connects the right and left steering knuckles. The worm (cam) shaft is supported by ball bearings. Design features provide caster, camber, and toe-in for easy steering and trouble free operation.

Creeper Attachment (Underdrive)

A four to one ratio unit is available for field application. This planetary gear reduction unit is mounted ahead of and is secured to the front of the reduction drive. A speed selection lever provides standard or "creeper" speed shifting as desired.

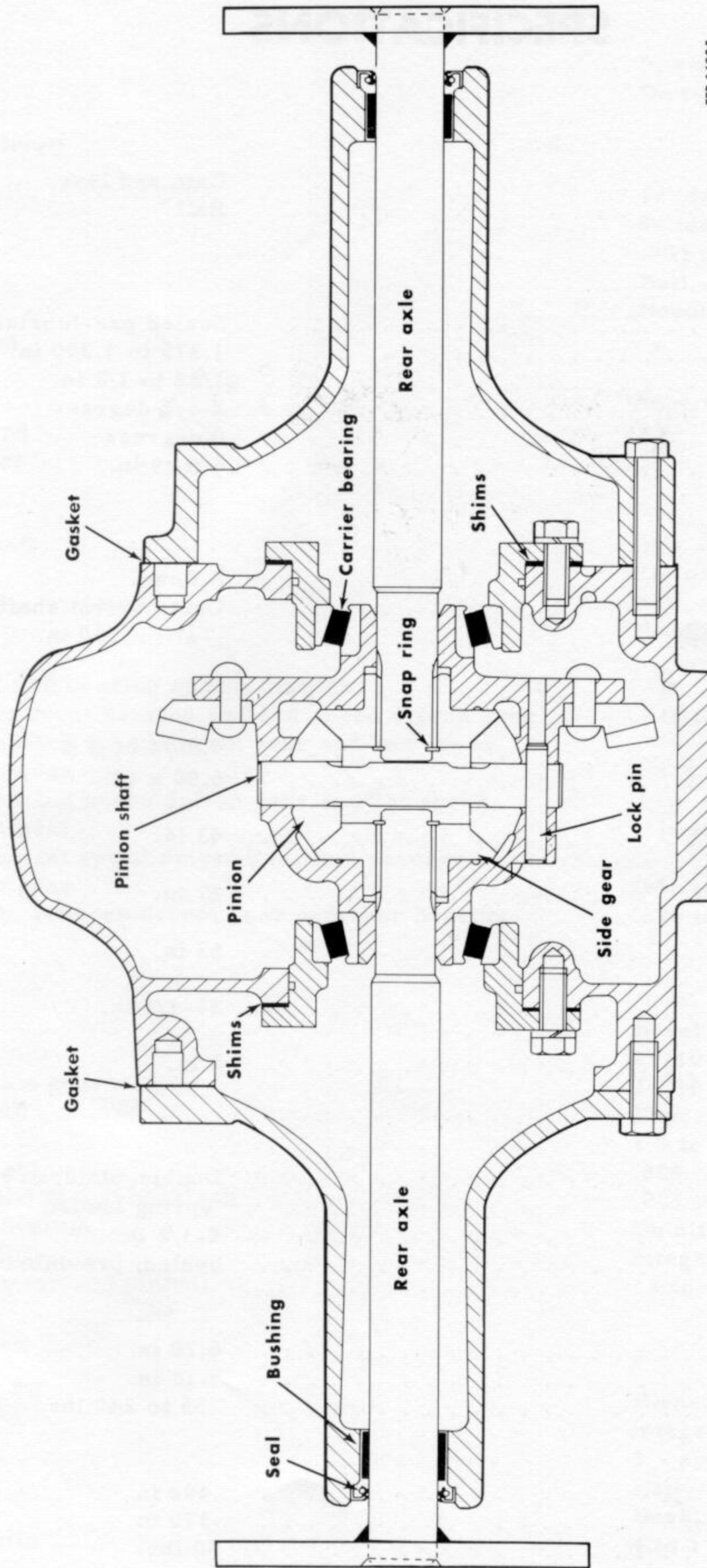

FEB-14035

Illust. 4. Cross section - rear axle assembly.

SPECIFICATIONS

Steering

Type	Cam and lever
Bearings	Ball

Front Wheels

Bearings	Sealed pre-lubricated ball
Hub I.D.	1.375 to 1.380 in.
Toe-in	1/32 to 1/8 in.
Camber angle	2-1/2 degrees
Caster angle	0 degrees
Turning radius	6 ft. 9 in.

Front Axle

Construction	I-Beam
Support	Center pivot shaft
Steering knuckle diameter747 to .750 in.

Tire Size

Front	4.80/4.00 x 8
Rear	6.00 x 12

Wheelbase 43 in.

Tread 27 in.

Length, Over-all 63 in.

Width, Over-all 33-1/4 in.

Ground Clearance 6 in.

Clutch

Type	Double-plate, dry disc, spring loaded
Size	4-1/2 in.
Clutch release bearing	Sealed, pre-lubricated ball

Clutch loading spring

Free length	6.70 in.
Test length	5.18 in.
Test load	235 to 240 lbs.

Clutch teasing spring

Free length442 in.
Test length370 in.
Test load	50 lbs.

Brake

Type	Internal caliper
Location	On transmission countershaft

Reduction Drive

Input shaft with integral gear	12 teeth
Driven gear	84 teeth
Backlash004 to .011 in.
Bearings	Ball - front Needle - rear

Transmission

Type	Selective sliding spur gears
Gears forward	3
Gears reverse	1

Bearings

Countershaft	Ball - front Roller - rear
Main shaft	Ball - front Needle - rear

Countershaft and bearing spacer lengths:

1. Between front bearing and 3rd speed driven gear848 to .852 in.
2. Between 3rd speed driven gear and 2nd speed driven gear1.310 to 1.314 in.
3. Between 2nd speed driven gear and 1st speed driven gear310 to .314 in.
4. Between 1st speed driven gear and reverse driven gear686 to .690 in.
5. Between reverse driven gear and rear bearing690 to .694 in.

Differential

Type	Bevel gears and pinions
Number of pinions	2 (10 teeth)
Number of side gears	2 (16 teeth)
Bearings (two)	Tapered roller
Pre-load	1.5 to 8.0 in. lbs.
Adjusting shims004, .007, .015, .030 in.
Bevel gear and pinion backlash003 to .005 in.
Bevel gear location	On differential case
Pinion location	Integral part of countershaft
Ratio (bevel gear and pinion)	13 to 46

Creeper Drive

Type	Planetary gears
Sun gear	Integral part of case
Planet gears	3 - spur type
Bearings	Ball - front Bushing - rear
Reduction ratio	4 to 1

STEERING ASSEMBLY

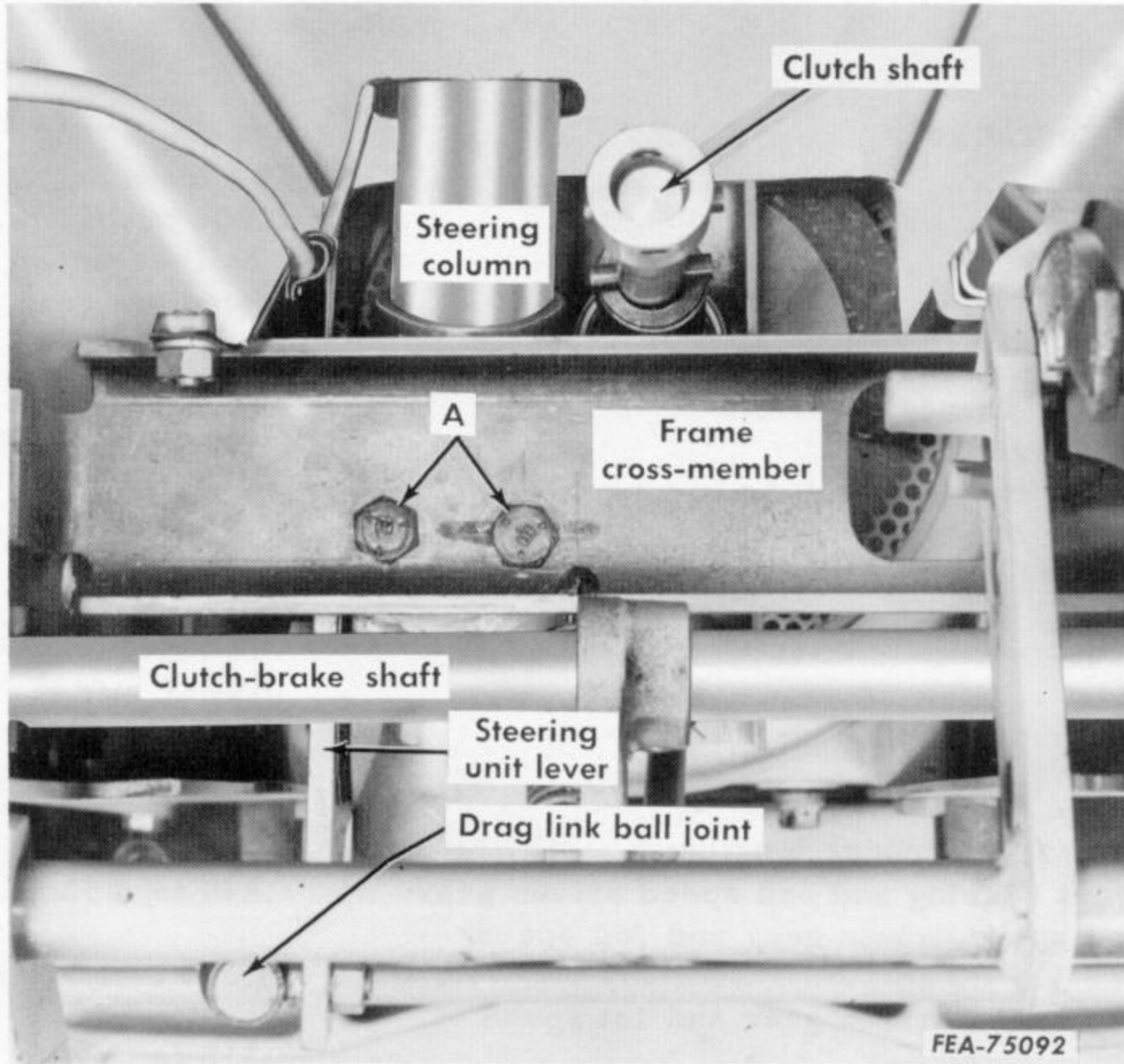

Illust. 5. Underside view of steering support and frame cross member.

Removal

1. Remove the steering wheel.
2. Remove the felt seal, retainer, bearing and bearing retainer from the upper end of the steering column.
3. Remove the drag link rear ball joint from the steering unit lever.
4. Remove capscrews "A" (Illust. 5) from the frame cross member and steering unit.
5. Lower the steering column assembly through the instrument panel pedestal and grommet.

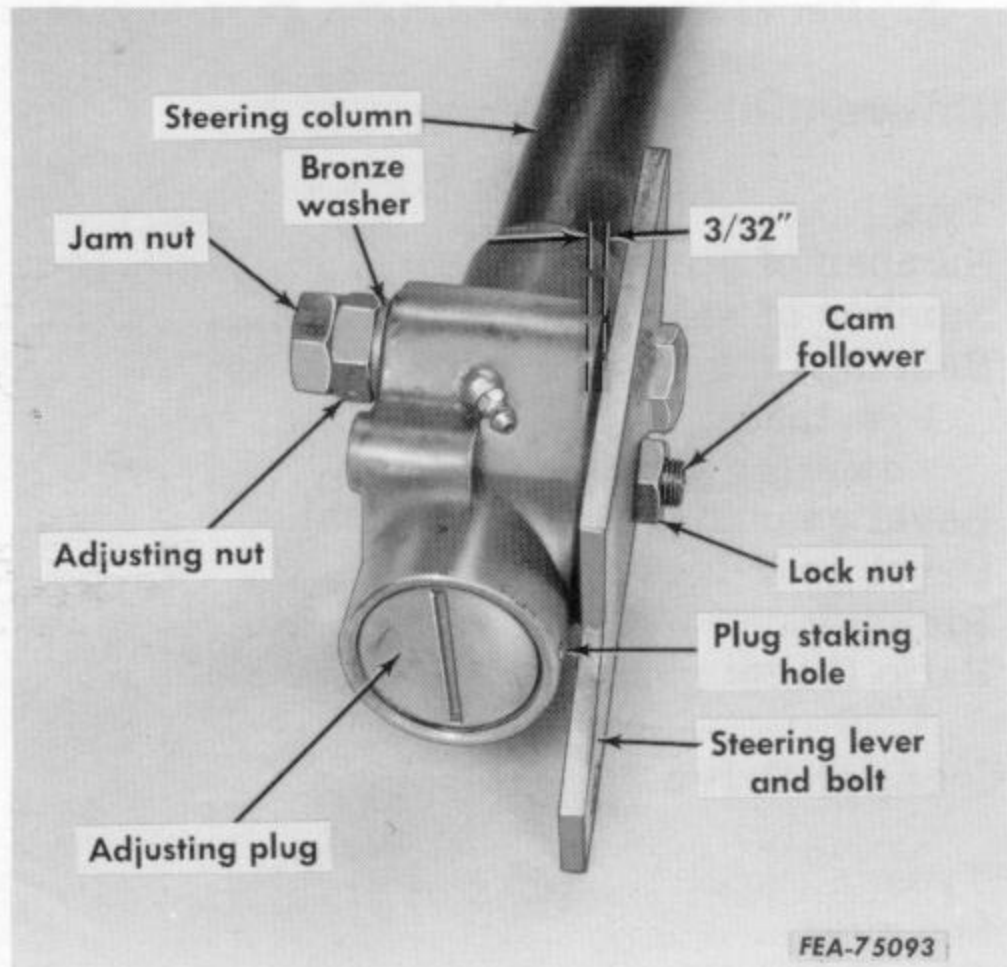

Illust. 6. Steering assembly.

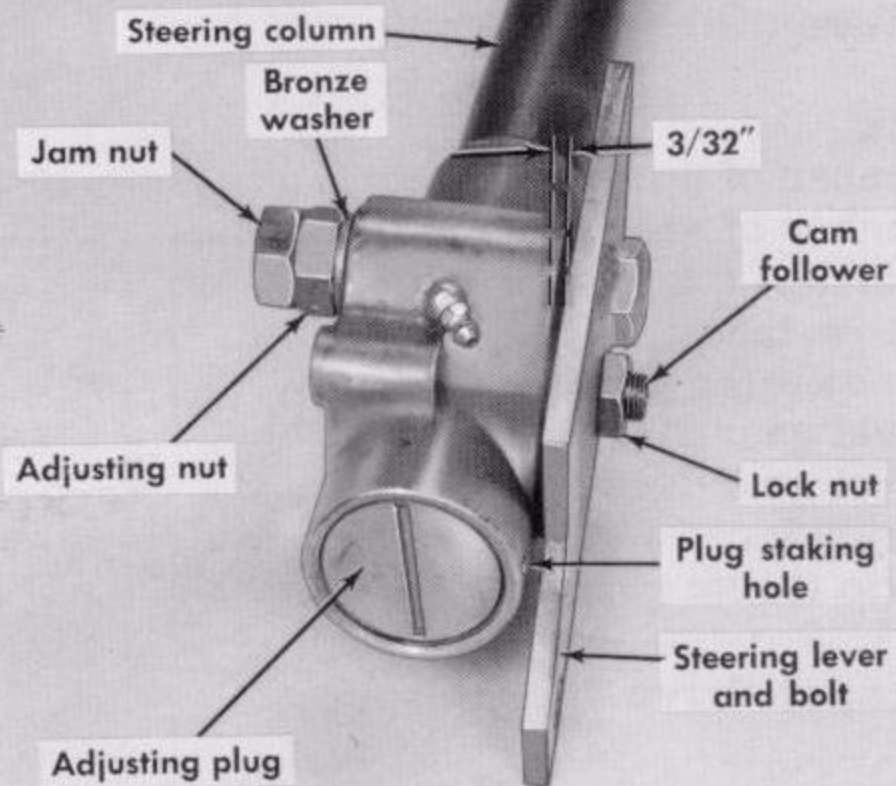

FEA-75093

Illust. 6. Steering assembly.

Disassembly

1. Secure the steering lever and bolt in a vise.
2. Remove the adjusting plug.
3. Remove the lever bolt jam nut, adjusting nut, and bronze washer.
4. Slide the column and housing assembly away from the lever, bolt and cam follower.
5. Remove the steering cam and bearings from the housing.
6. Remove the bearing race retainer snap rings.

Inspection and Repair

1. Wash all parts in cleaning solvent, then dry thoroughly.

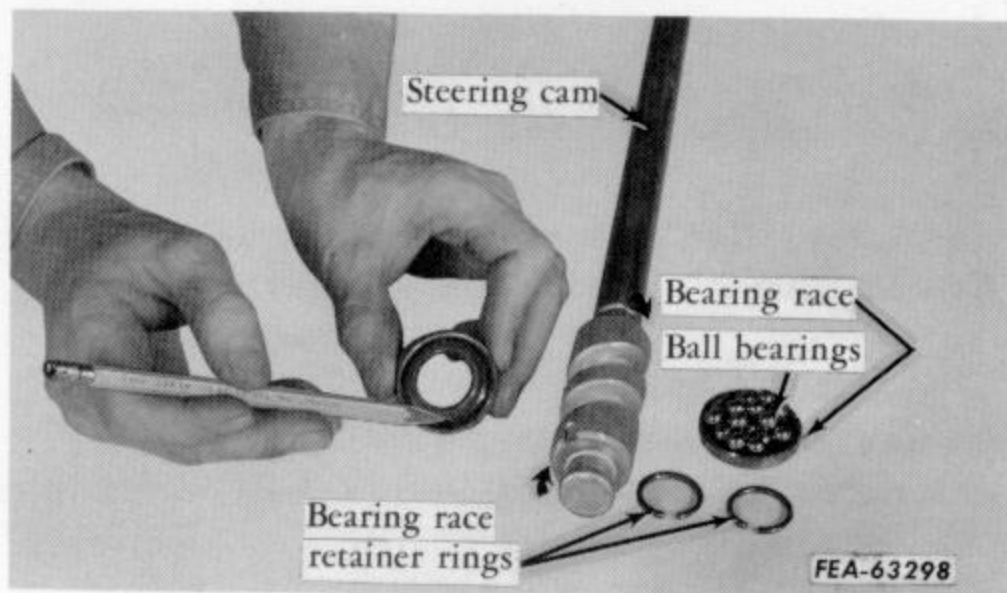

Illust. 7. Inspection of steering cam, bearings and races. Arrows and pencil indicate areas for inspection.

2. Inspect the cam follower for wear (flat spots).
3. Inspect the cam ends, bearings and races for wear, roughness and pitting.
4. Inspect the cam grooves for wear, roughness and galling.

5. Inspect the housing for cracks and stripped threads.

6. Inspect the upper bearing (nylon bushing) for wear or damage.

Reassembly and Adjustment

1. Thoroughly coat the cam ends, balls and races with chassis lubricant.
2. Install the balls and races on the cam ends and secure with their retaining snap rings.
3. Thoroughly coat the cam and bearings with chassis lubricant then install them into the housing and column assembly.

NOTE: Be sure the races enter the housing squarely and are not "cocked."

4. Install the adjusting plug. Screw the plug inward until end play (of the cam) is removed and the cam turns free.

5. Stake the plug by inserting a small center punch through the housing holes and spread the plug threads to keep the plug from loosening.

6. Fill the housing with chassis lubricant.

7. Loosen the cam follower locknut, then "back out" the cam follower one turn.

8. Install the seal, retainer and lever-bolt assembly to the housing.

9. Install the bronze washer and adjusting nut. Tighten the adjusting nut sufficient to provide good seal compression. Refer to Illust. 6 for adjustment dimensions. Secure with the jam nut. Tighten jam nut to 40 ft. lbs. Lubricate the lever-bolt at the fitting.

10. "Center" the steering cam by rotating the steering shaft half way between full right and full left turn.

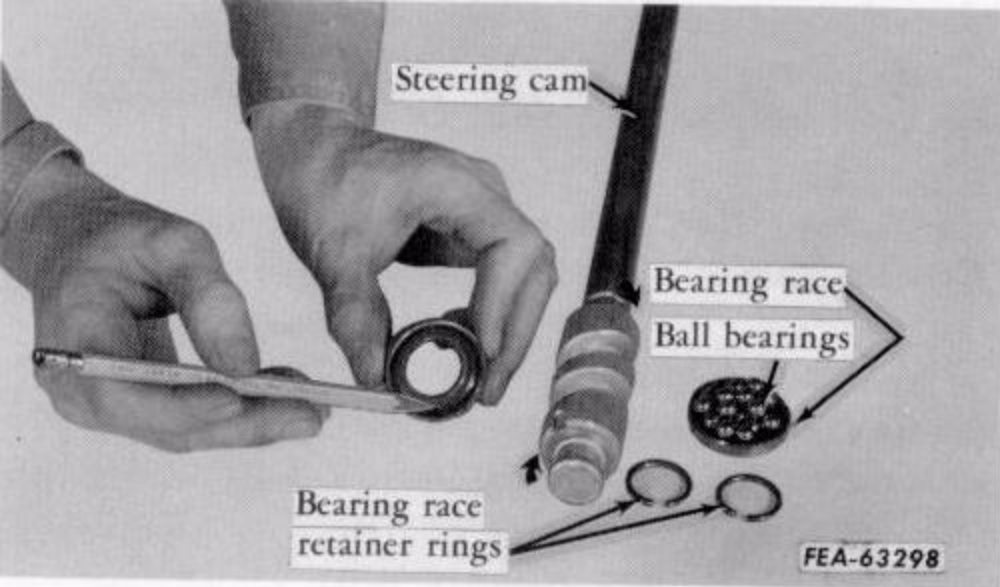

Illust. 7. Inspection of steering cam, bearings and races. Arrows and pencil indicate areas for inspection.

11. Adjust the cam follower inward to eliminate backlash, then tighten locknut to 60 ft. lbs. Turn steering shaft full right and left to check for binding.

12. Replace the steering assembly in the tractor chassis. Secure with two cap-screws through the frame cross member.

13. Connect the drag link.

14. Install the upper column bearing, retainer, felt seal and retainer.

15. Replace the steering wheel and secure with nut.

16. Adjust the drag link "D" (Illust. 8) to proper length to place front wheels in the straight ahead position when the steering assembly is "centered."

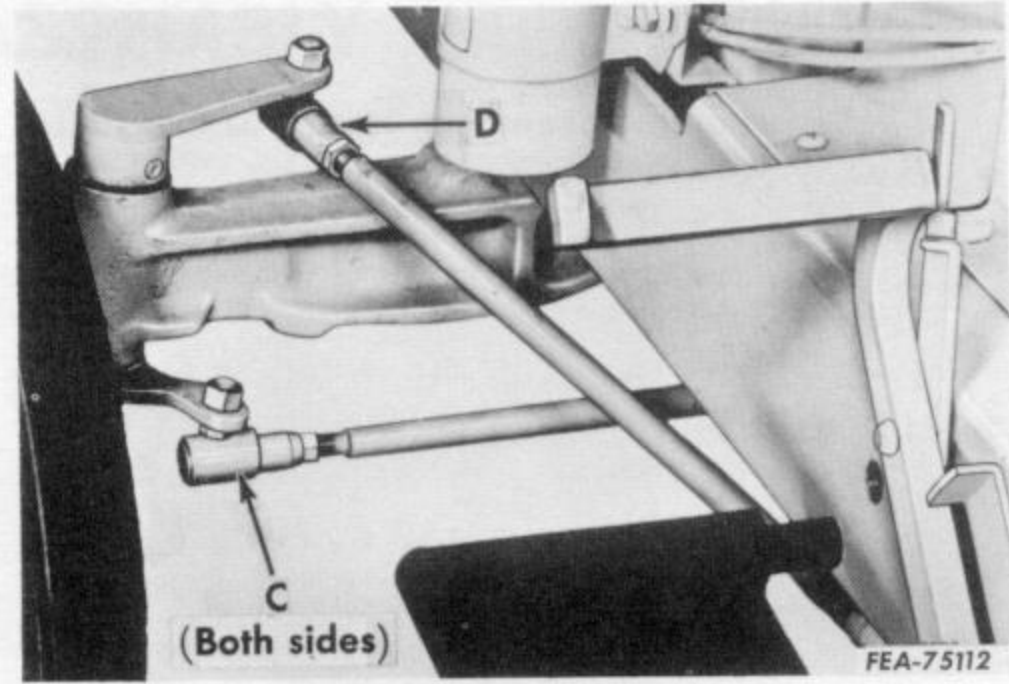

Illust. 8. Steering tie rod and drag link ball joints.

17. Adjust tie rods "C" (Illust. 8) to provide 1/32" to 1/8" toe-in.

FRONT WHEELS AND BEARINGS

Removal

1. Lock the brake and block the rear wheels. Jack up the front axle.

2. Remove the capscrew and flat washer from the outer end of the front spindle.

3. Slide the wheel and bearings from the spindle.

NOTE: The bearings are a press fit in the wheel and a slip fit on the spindle.

Disassembly

1. Wheel bearings can be driven from the wheel hub with a hammer and long drift punch. Drive from the inside toward the outside.

Inspection and Repair

1. Inspect the entire wheel and hub for weld separation, split hub tube and rim bending.

2. Bearings should be inspected for wear, seizure and seal condition.

Reassembly

1. If the bearings were removed, press in new ones. Be sure force is directed to the outer race only when being pressed in.

NOTE: These wheels may be used on older model cub cadet tractors by pressing in service bushings instead of ball bearings.

Installation

1. Slide the wheel and bearing assembly over the spindle and secure with capscrew and flat washer.

2. If excessive end play exists, place a sufficient thickness of shim washers (3/4" ID) over the outer end of the spindle and between the retaining washer and wheel bearing.

FRONT AXLE

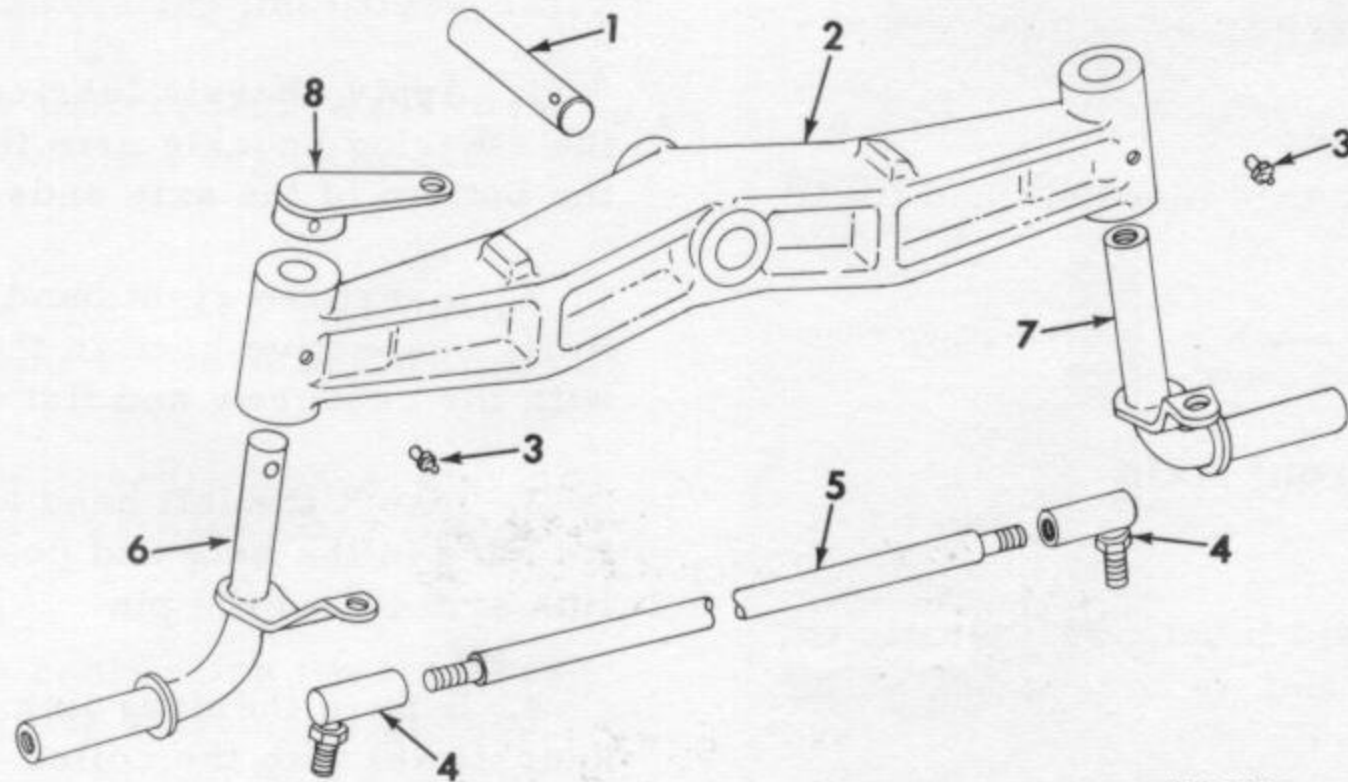

FEA-75113

Illust. 9. Front axle components.

Steering Knuckle Removal (Illust. 9)

1. Lock the brake, jack up the front of the tractor and support it on a suitable stand.
2. Remove the front wheels.
3. Disconnect the tie rod ball joints (4) from left steering knuckle (6) and right steering knuckle (7).
4. Using a pin punch and hammer, drive out the coiled spring pin from the drag link arm (8) and steering knuckle (6).
5. Remove the steering knuckle (6) from the axle (2).
6. Remove the capscrew and flat washer from the upper end of the steering knuckle (7).
7. Remove the steering knuckle (7) from the axle (2).

Removal of Front Axle

1. Disconnect the drag link ball joint "D" (Illust. 8) from the drag link arm (8) (Illust. 9).

2. With the front of the tractor frame supported by a suitable stand, drive out the retaining pin from the front of the axle pivot pin (1) (Illust. 9).

3. Remove the pivot pin (1). The front axle (2) is now free of its mounting and can be removed (Illust. 9).

Inspection and Repair

1. Inspect all parts closely for wear, bending and breaks.



FEA-63393

Illust. 10. Checking wear in front axle for steering knuckle pins.

2. Check fit of steering knuckle pivot pins to their respective bore in the axle. Each part may be checked with micrometers and snap gauges to determine the extent of wear.

3. Check front axle pivot pin and its fit in the axle.

Reassembly of Front Axle

1. Apply chassis lubricant liberally to the axle pivot pin and its bore in the axle.

2. Position the axle in its support bracket channel, align the pivot pin holes and insert the pin.

3. Align the retaining pin holes (through the front of the pivot pin and through the front collar of the support bracket) then drive the retaining pin through both parts.

Reassembly of Steering Knuckles

(Illust. 9)

1. Apply chassis lubricant liberally to the steering knuckle arm thrust surface and the bottom of the axle ends.

2. Insert the right hand knuckle pin (7) in its respective bore in the axle and secure with the capscrew and flat washer.

3. Insert the left hand knuckle pin (6) in its bore in the axle and position the drag link arm (8) on the pin.

4. Secure the drag link arm (8) and knuckle (6) with the coiled spring pin.

NOTE: Spring pin must extend through the drag link arm an equal amount on each side.

5. Install the tie rod (5).

6. Install the front wheels and check toe-in adjustment.

CLUTCH

Removal

Complete service of the clutch shaft, loading spring, release bearing, and cushion spring will require removal of the tractor engine, then the clutch assembly.

Refer to GSS-1350 Engine Manual for engine removal procedure then remove the clutch shaft coupling rear pin, clutch release lever pin, and disconnect the clutch release rod from the pedal arm.

When minor service (replacing the driving disk, driving plate or pressure plates) only is required, perform the following steps 1 through 13.

1. Depress the clutch and brake pedal and lock it.

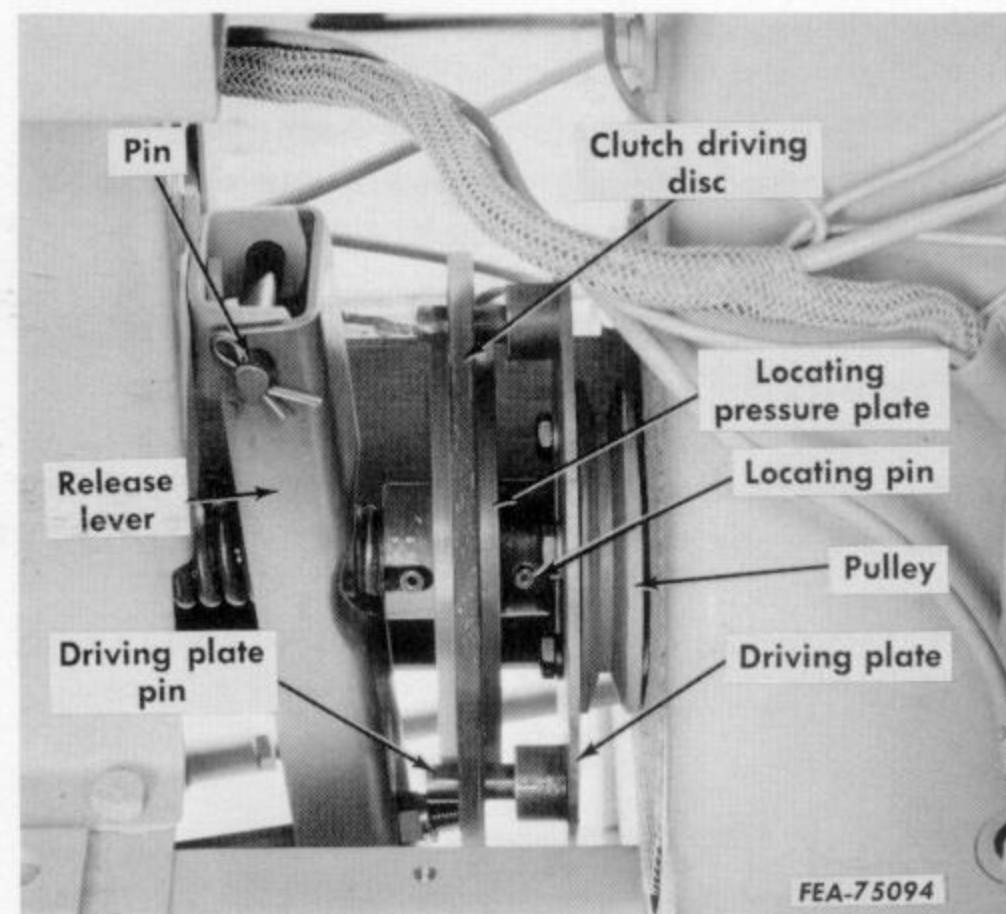

Illust. 11. Clutch shield removed showing clutch drive.

2. Remove the clutch shield.
3. Using a hammer and punch, drive out the pressure plate locating pin (Illust. 11).
4. Remove the four capscrews (two on each side) which hold the engine to the tractor frame.
5. Release the clutch and brake pedal, then slide the engine forward in the frame.
6. Replace the pressure plates, driving disk or driving plate as necessary (Illust. 11).

NOTE: Wiring cable clips (on tractors equipped with electric starting) will need spreading so that wires can follow engine as it is moved forward.

7. Slide the engine rearward while aligning the clutch shaft and driving plate pins (Illust. 11).
8. Depress and lock the clutch-brake pedal.
9. Replace the pressure plate locating pin (Illust. 11).
10. Align the engine to the frame and replace the securing capscrews.
11. Secure the wires and cables in their clips.
12. Connect the ground cable (if it was disconnected).
13. Replace the clutch shield.

Disassembly

1. Clamp the clutch shaft in a vise as shown in Illust. 12 and drive the coiled spring pin out.
2. Slowly release the vise allowing the spring to extend as the shaft slips through the vise jaws.

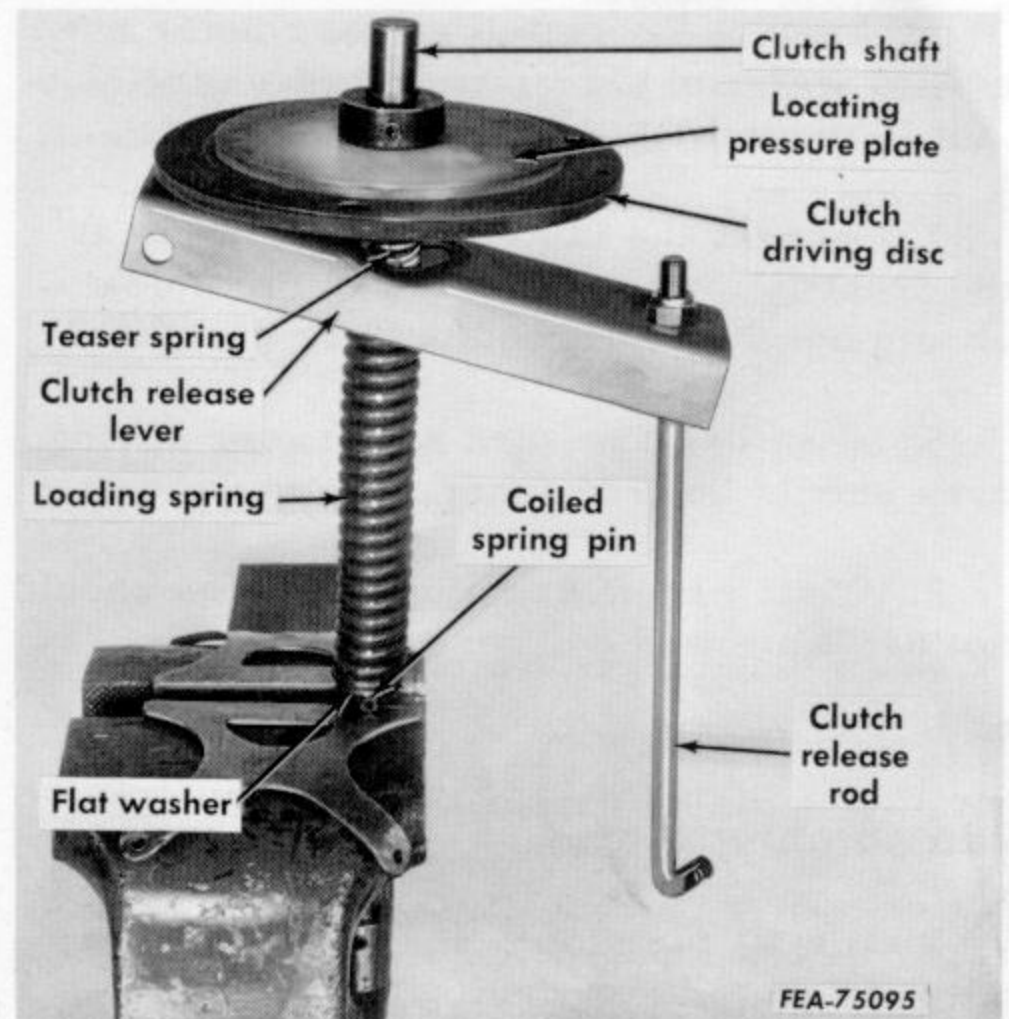

Illust. 12. Clutch shaft secured in vise for removal of pin.

3. Support the hubs of the pressure plates, then drive their coiled spring pins out.
4. Support the clutch shaft coupling, then drive the coiled spring pin out.

Inspection and Repair

1. Inspect the clutch driving disk for wear from pressure plates and for elongated holes from the driving plate pins. Disk must be free of grease and oil.
2. Inspect both pressure plates for wear on their contact faces.
3. Inspect the slotted hub of the rear pressure plate for pin wear. If the slots are cupped from pin wear the plate must be replaced.
4. Inspect the teaser spring ends. Ends should be rounded to prevent gouging the clutch shaft. Check the spring tension (see Spec's).
5. Inspect the loading spring ends. Ends should be rounded to prevent gouging the clutch shaft. Check the spring tension (see Spec's).

6. Inspect the clutch release lever channel for wear on the curved area where contact is made with the release bearing.

7. Inspect the clutch shaft for wear at the front (pilot bushing area). Pin holes should not be "wallowed out" or elongated.

Release bearing area and teaser spring area should be free from scoring.

8. Clutch shaft coupling pin holes should not be "wallowed out" or elongated.

Reassembly

1. Install the clutch shaft coupling onto the rear end of the shaft, align the pin holes and secure by installing the coiled spring pin.

2. Install parts to the clutch shaft in the following sequence: flat washer, loading spring, flat washer, release bearing (long sleeve end forward), release lever (channel flanges toward rear) and the teaser (cushion) spring.

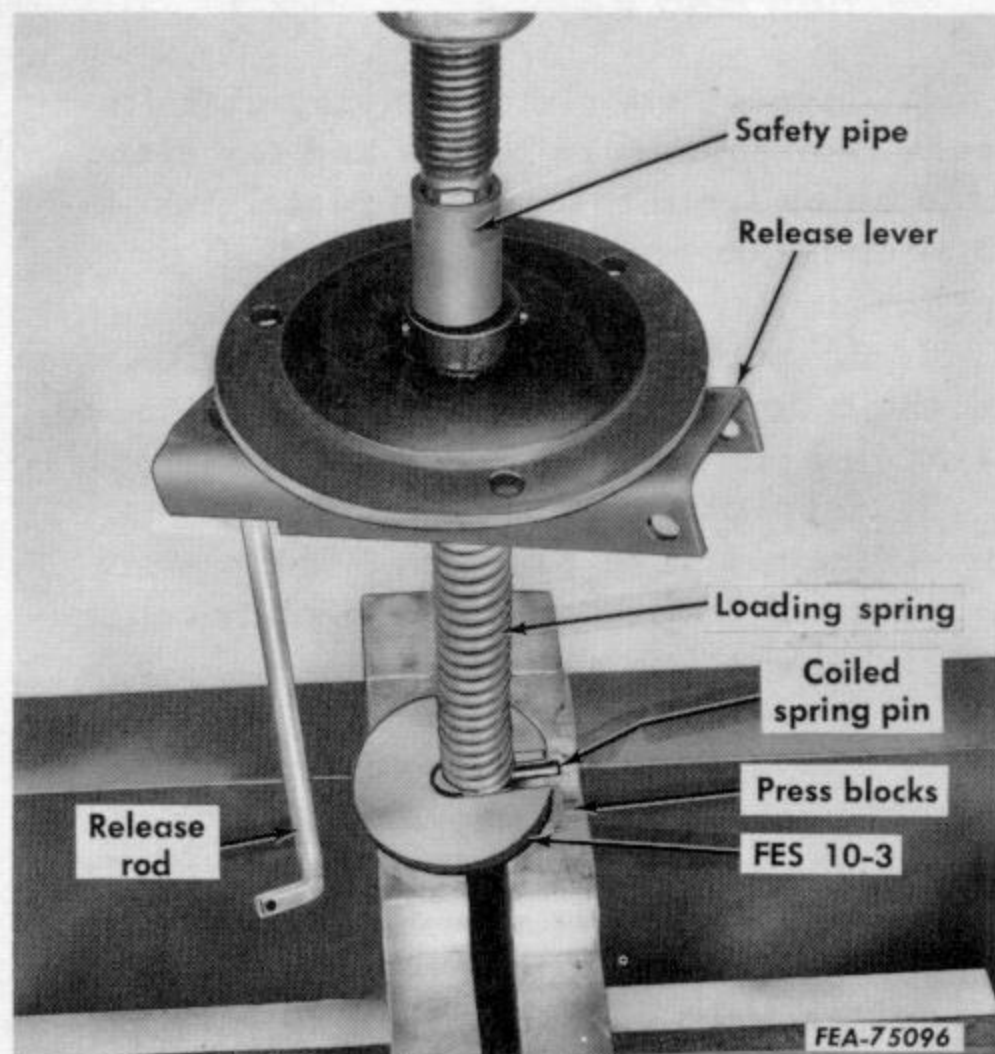

Illust. 13. Compressing the loading spring for pin installation.

3. Install coiled spring pin through the shaft (second hole from shaft front end).

4. Install rear pressure plate over shaft so that pin slots in the hub engage the pin.

5. Install the friction driven disk and the locating pressure plate.

6. Align the pin holes of the shaft and locating pressure plate hub and secure with coiled spring pin.

7. Apply chassis lubricant or "Lubriplate" to that area of the clutch shaft which will be covered by the teaser spring and release bearing.

8. Place the assembly in a press as shown in Illust. 13. Center the clutch driven disk and compress the loading spring sufficient to install the coiled spring pin.

Installation and Adjustment

1. Place the clutch shaft over the frame cross member and move it rearward to engage the coupling to the reduction unit or "creeper" drive shaft.

2. Align the release lever to its bracket, install the pin and secure with cotter.

3. Apply chassis lubricant or "Lubriplate" liberally to the clutch shaft pilot bushing.

4. Slide the engine rearward while aligning the clutch shaft into its pilot bushing and the drive plate pins into their holes in the driven disk.

5. Align the engine mounting capscrew holes and install the capscrews.

6. Align the clutch shaft coupling rear pin hole with pin hole in reduction drive (or "creeper" drive) shaft and install the pin.

7. Connect the clutch release rod to its pedal shaft lever and secure with the return spring.

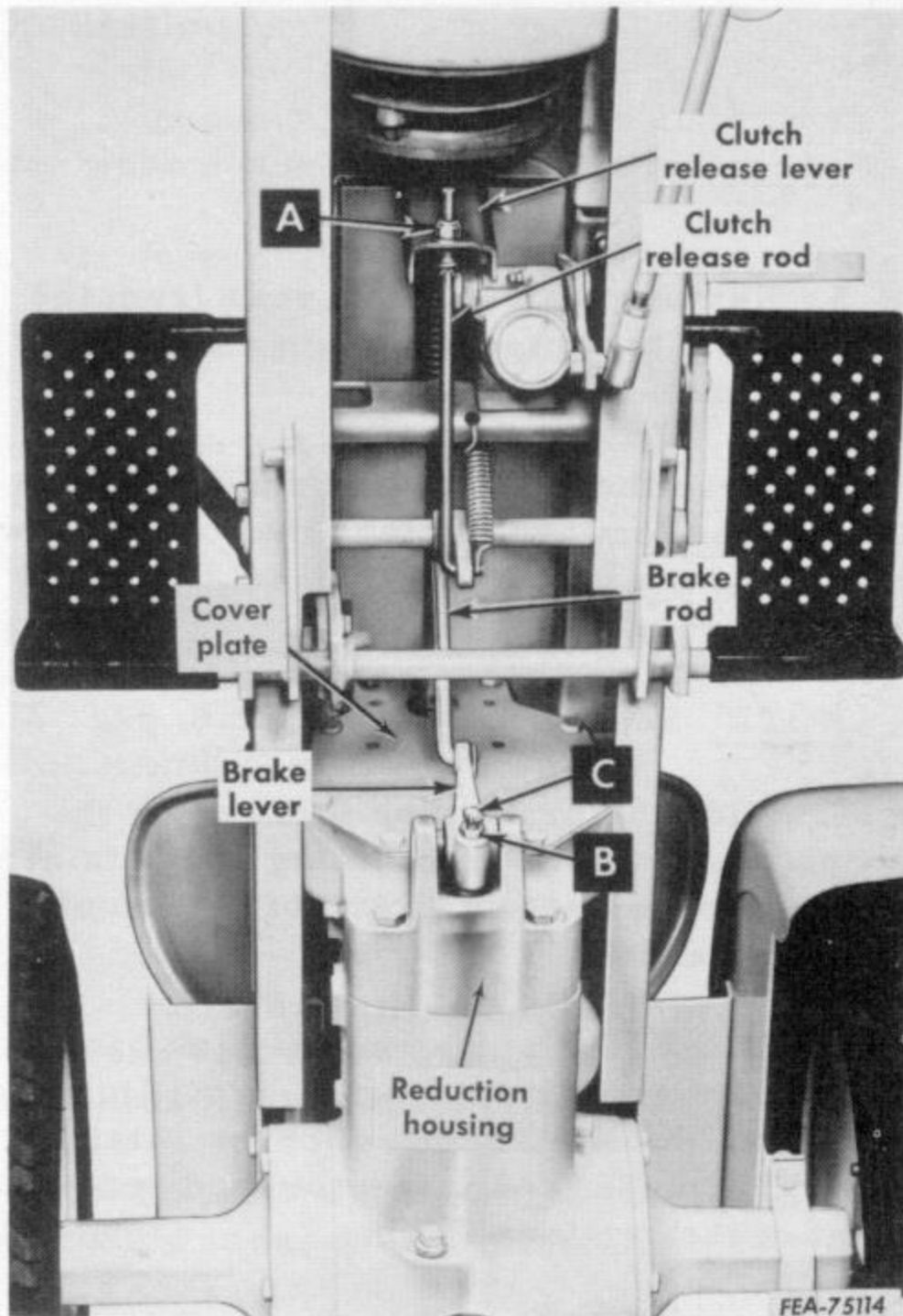

Illust. 14. Underside view of brake and clutch control linkage.

8. Depress the pedal and release the clutch to allow components to move into final alignment.

9. Tighten the engine mounting cap-screws.

10. Position the wires and cables in their clips and secure.

11. Connect the battery ground cable.

12. Replace the clutch shield.

13. Check the clutch pedal and linkage for proper adjustment. Refer to Illusts. 14 and 15.

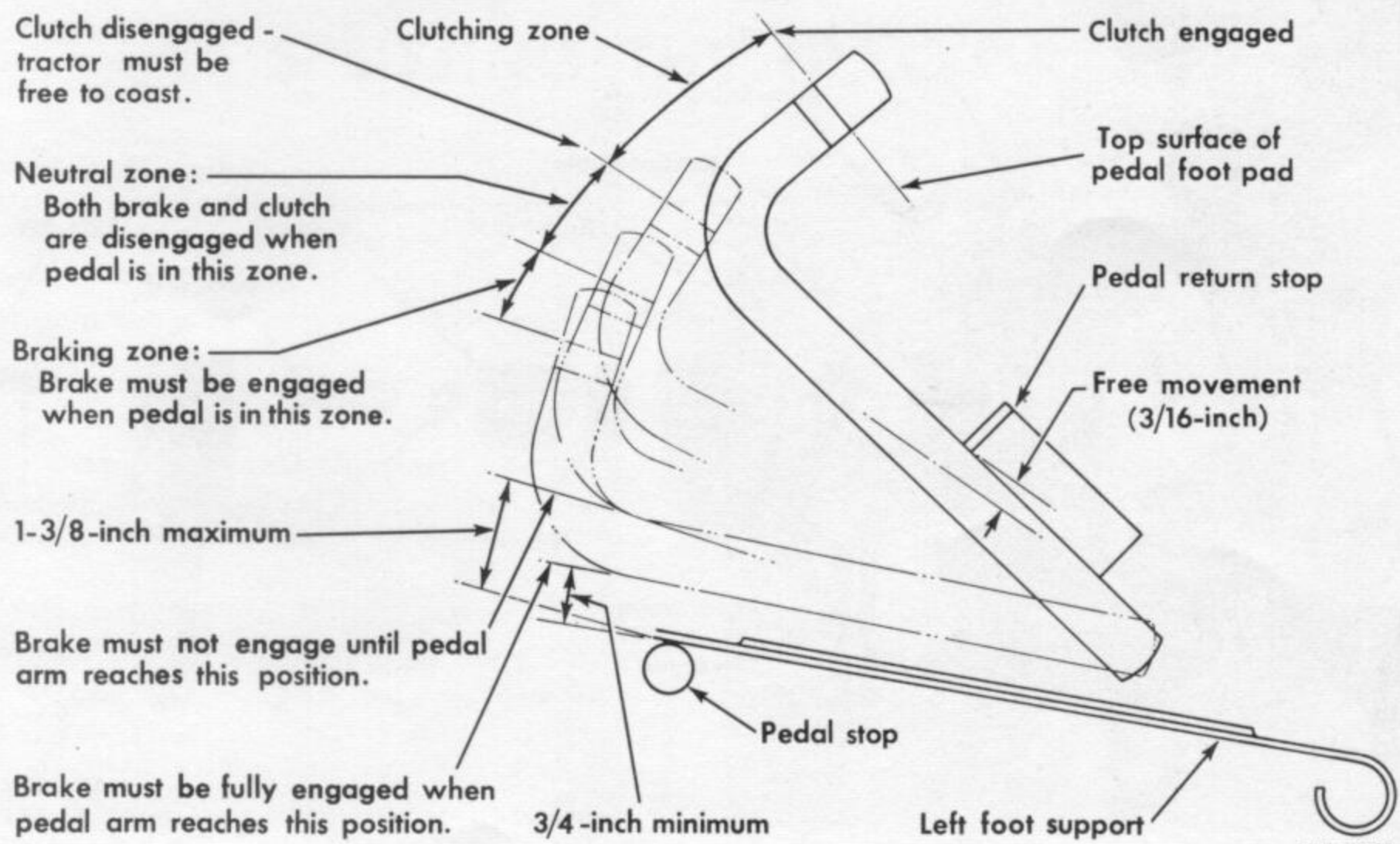

Illust. 15. Clutch and brake pedal linkage adjustments.

BRAKE

Tractors equipped with a "creeper" attachment will require "splitting", and the creeper removed before complete brake service can be performed. Refer to page 19 of this manual for splitting procedure.

Removal

1. Drain the transmission lubricant.
2. Remove the brake adjusting screw "C" and jam nut "B" from its lever (Illust. 14).
3. Remove the brake lever, pivot pin and push rod (Illust. 16).
4. Remove the reduction housing front cover plate and slide it forward on the clutch shaft (Illust. 14).

5. Remove the reduction gear from the front of the transmission main shaft. Refer to Illusts. 3 and 21.

6. Move the gear upward and the bottom of the gear forward to clear the cover screw bosses as the gear is lifted from the housing.

NOTE: See NOTE, paragraph 6, page 21.

7. Slide the brake disk forward on the countershaft as the front lining and retainer are moved forward in their bore. Refer to Illusts. 3 and 16.

NOTE: Both linings and the disk can be removed without removing the front lining retainer; however, removal of the retainer is recommended for inspection and replacement of the retainer O-ring.

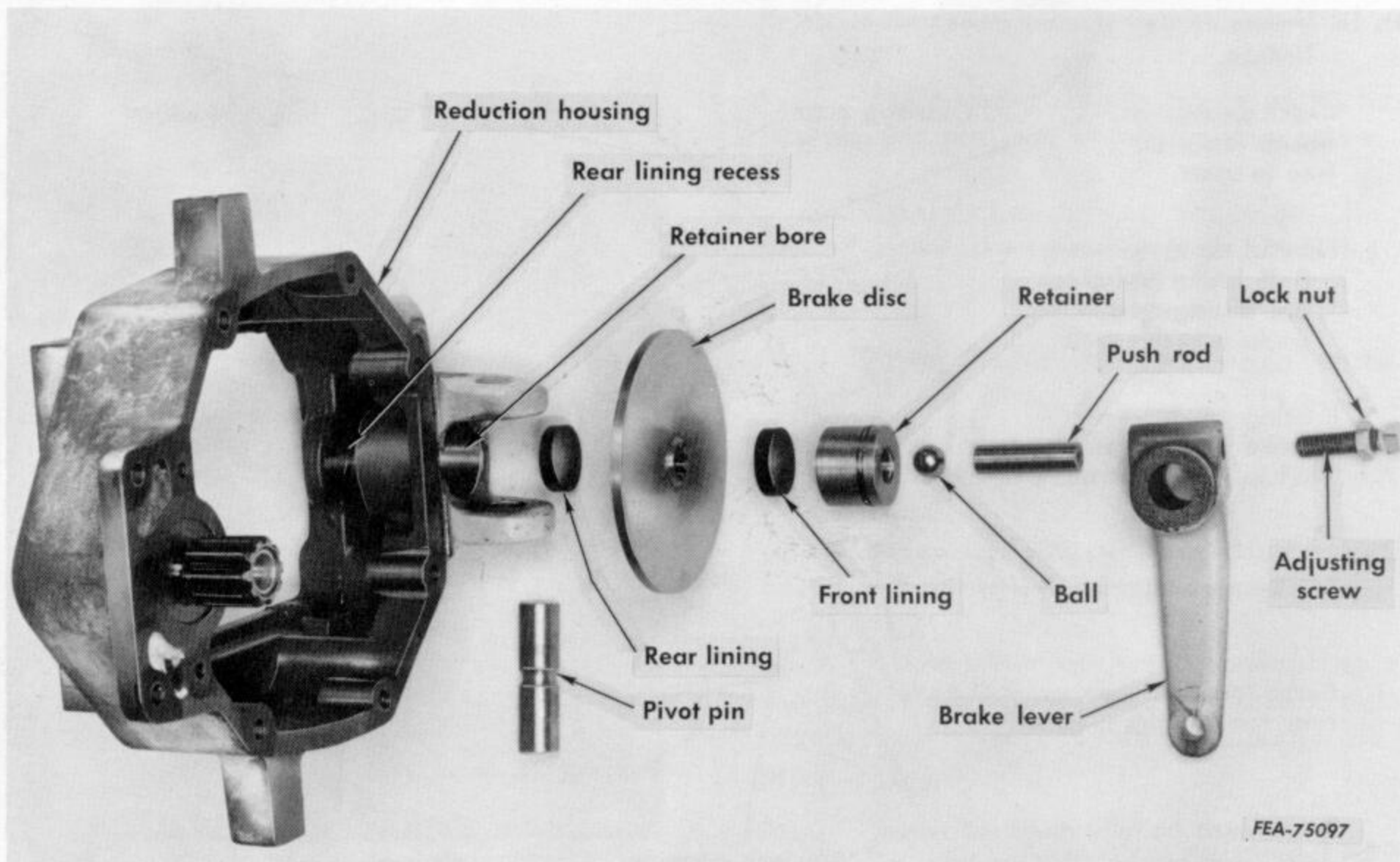

Illust. 16. Exploded view of brake components and reduction housing.

Inspection

1. Inspect the control rods and levers for wear at their connecting pivot points.
2. Inspect the linings and disk for wear.
3. Inspect the disk hub splines for wear.
4. Check the splines on the countershaft for wear.
5. Check the pedal return spring ends for wear.

Reassembly and Adjustment

1. Clean the brake cavity and lining recess in the reduction housing.
2. Place a small quantity of grease in the rear brake lining recess in the reduction housing then insert the lining.
3. Install the disk on the countershaft and slide it rearward against the rear lining.

4. Install a new O-ring on the front lining retainer, lubricate the retainer and O-ring then push them into the retainer bore in the reduction housing.

5. Install the front lining in the retainer lining recess and push the retainer and lining rearward against the disk.

6. Install the reduction gear on the transmission main shaft and secure with flat washer, lock washer and capscrew. Tighten capscrew to 55 ft. lbs.

7. Install a new cover gasket, then replace the cover plate.

8. Be sure the ball is in place in the front lining retainer then replace the push rod, lever, pivot pin, adjusting screw and lock nut.

9. Refer to Illusts. 14 and 15 for adjustment.

10. Fill transmission to proper level with Hy-Tran fluid or SAE 30 engine oil as specified in the Operator's Manual.

SPLITTING THE TRACTOR

1. Remove the fenders and their support brackets (if tractor is so equipped).

2. Remove the seat and its support bracket.

NOTE: Disconnect tail light wire at junction under seat support (if tractor is so equipped).

3. Remove the clutch shaft coupling rear pin. (Connects coupling to creeper or reduction drive shaft).

4. Drive a small wooden wedge between the front axle and frame on each side as shown in Illust. 17.

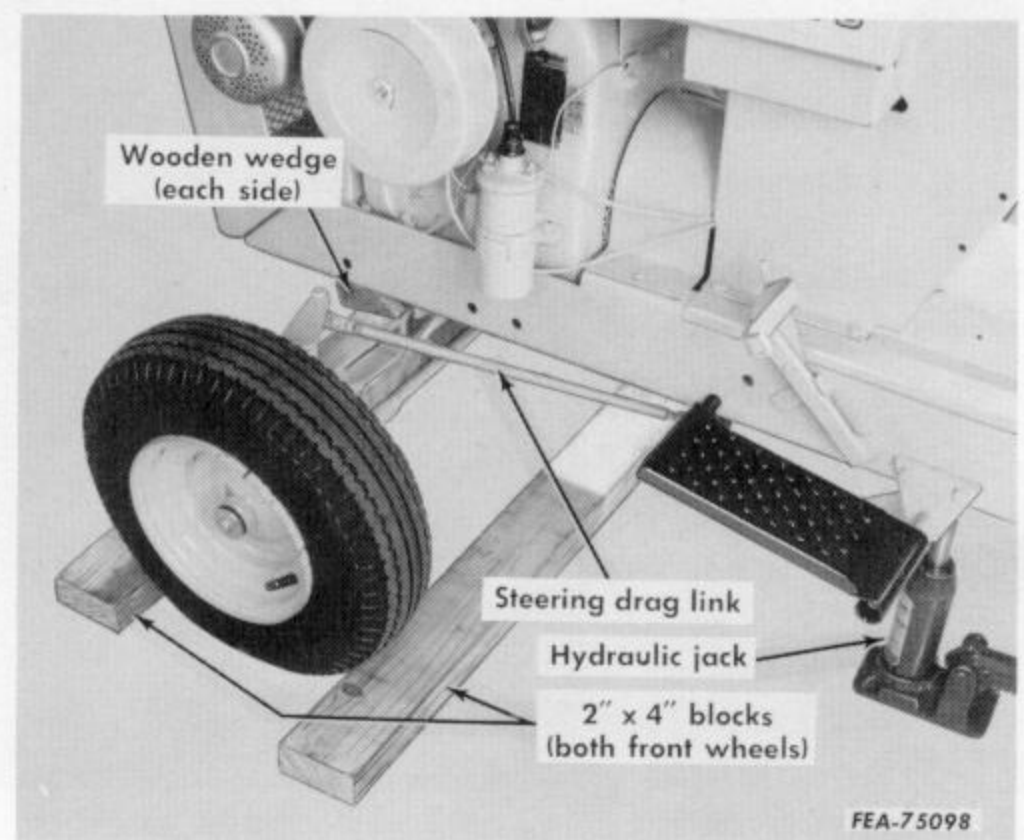

Illust. 17. Front axle and wheels wedged and blocked for tractor split.

5. Block both front wheels as shown.

6. If tractor is equipped with creeper attachment, shift the lever forward then remove the lever knob and the breather.

7. Disconnect the brake rod from the brake lever.

8. If tractor is equipped with three-point hitch, remove the lift bar and its attaching plate. See Illust. 19 insert.

9. Place a jack under the implement lift handle cross-shaft to support the frame. Refer to Illust. 17.

10. Remove three capscrews from each side of frame.

NOTE: Capscrews hold frame to the rear axle, transmission and reduction drive housings. Holes in frame are seen in Illust. 19.

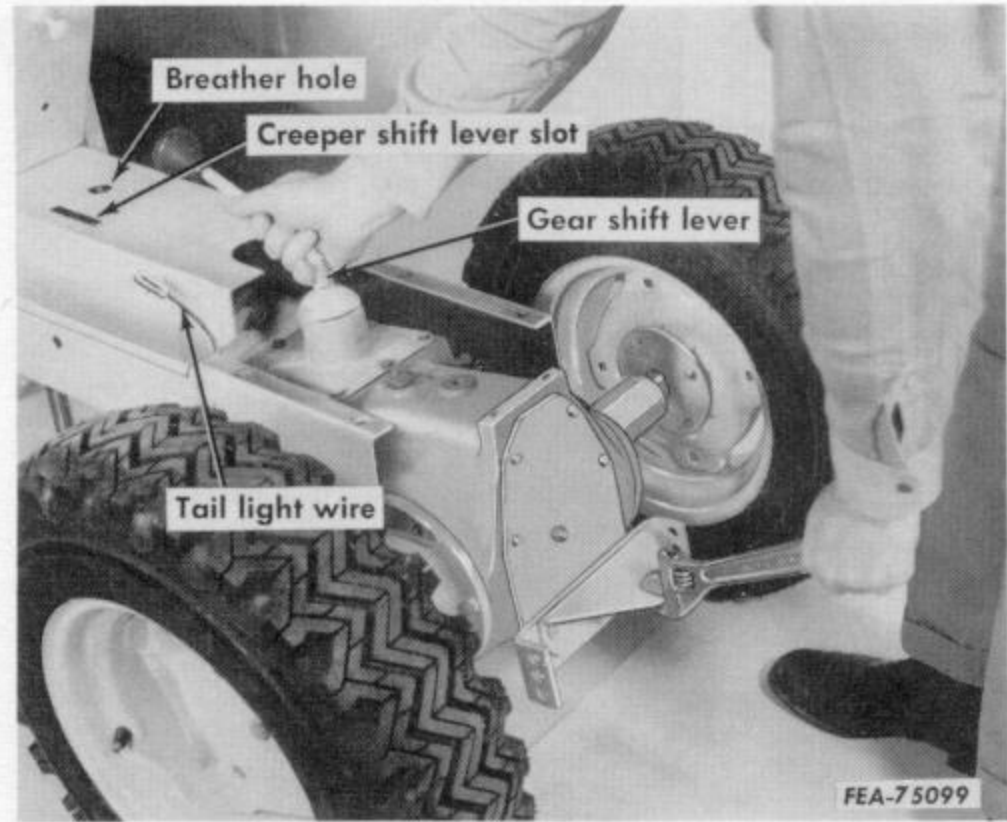

Illust. 18. Splitting the tractor.

11. Push down on the drawbar and pull rearward on the transmission shifter lever. Refer to Illust. 18.

Move the transmission-differential-rear end assembly rearward far enough to disengage from the clutch shaft coupling.

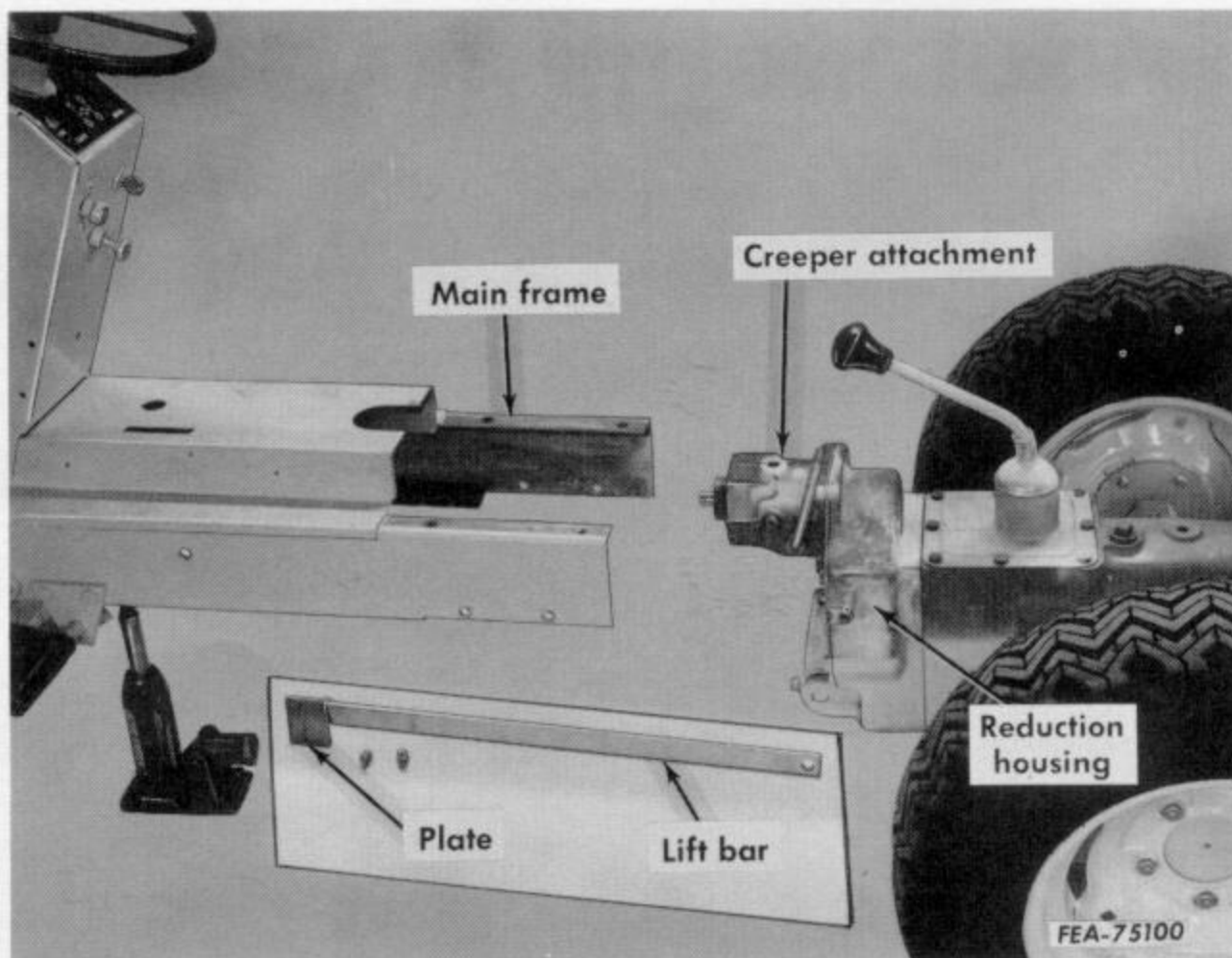

Illust. 19. Tractor split for service of creeper, reduction drive, transmission and differential.

Lower the front end (creeper) to clear creeper shift lever through frame slot, then assembly can be moved rearward and away from the frame.

12. Support the transmission housing on a stand or block and drain the lubricant if internal service is to be performed.

13. Recoupling of the tractor is basically the reverse of splitting; however, precautions should always be taken to safeguard against damage to shafts, bearings, seals etc. when aligning and securing components which work together. Always use recommended lubricants as specified in the Operator's Manual.

REDUCTION DRIVE

Removal and Disassembly

1. Split the tractor. Refer to page 19 this manual for splitting procedure.
2. Place an oil pan under the reduction housing and remove the creeper assembly (if tractor is so equipped).

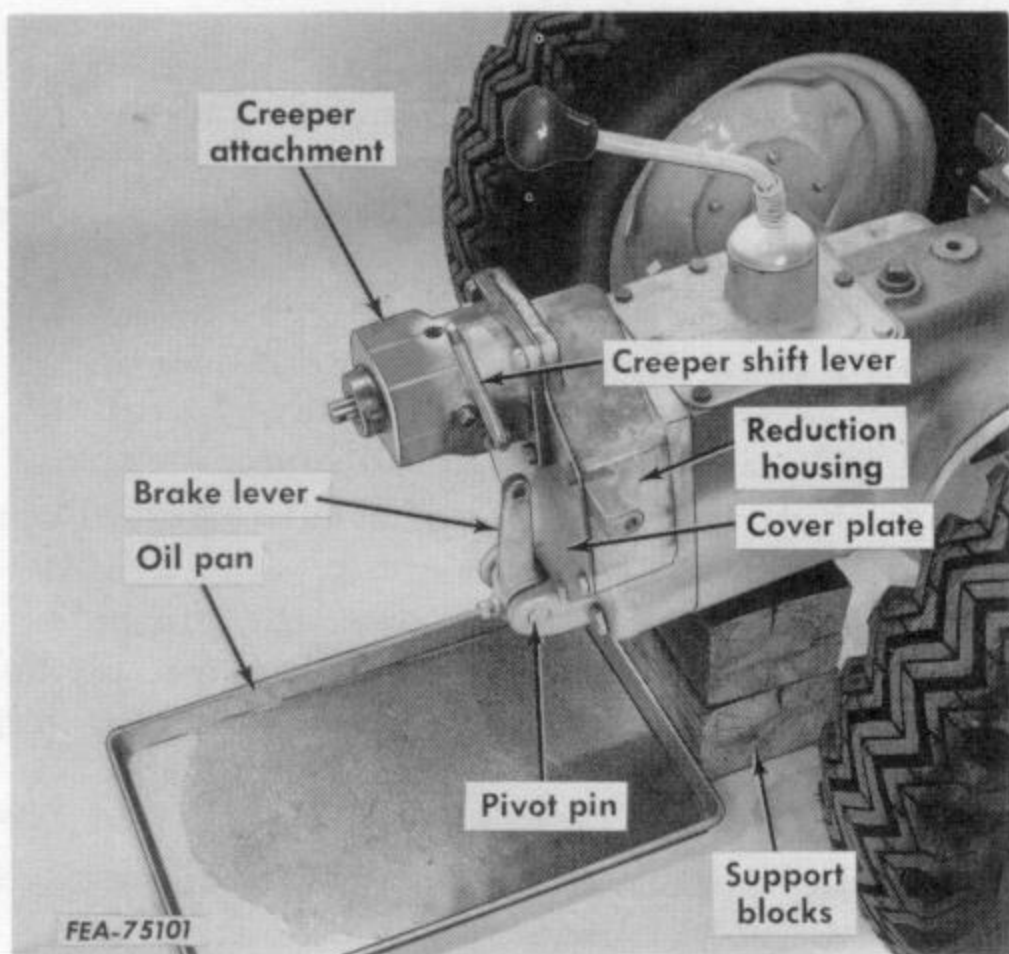

Illust. 20. Power train supported for disassembly.

3. Remove the brake lever, pivot pin and push rod (Illust. 20).
4. Remove the reduction housing front cover plate (Illust. 20).

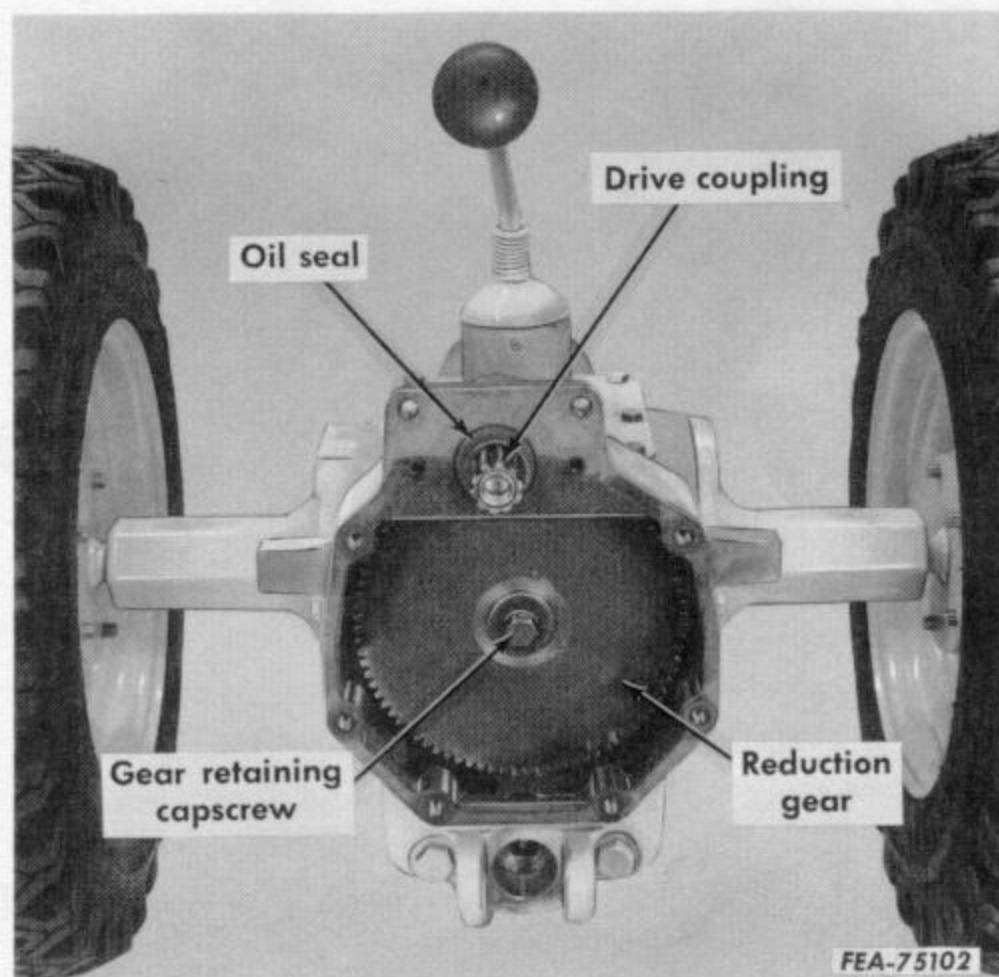

Illust. 21. Reduction drive exposed.

5. Hold the drive coupling and shaft from turning and remove the reduction gear retaining capscrew and washers. Remove the gear spacer (Illust. 21).

6. Remove the reduction gear from the transmission shaft and from the housing.

NOTE: It may be more convenient to pull the reduction drive shaft, seal and bearing as shown in Illust. 22 before removing the reduction gear from the housing. Clearance between the gear and the capscrew bosses is restricted on some tractors.

7. Remove capscrews from holes "A" and "B" (Illust. 22).

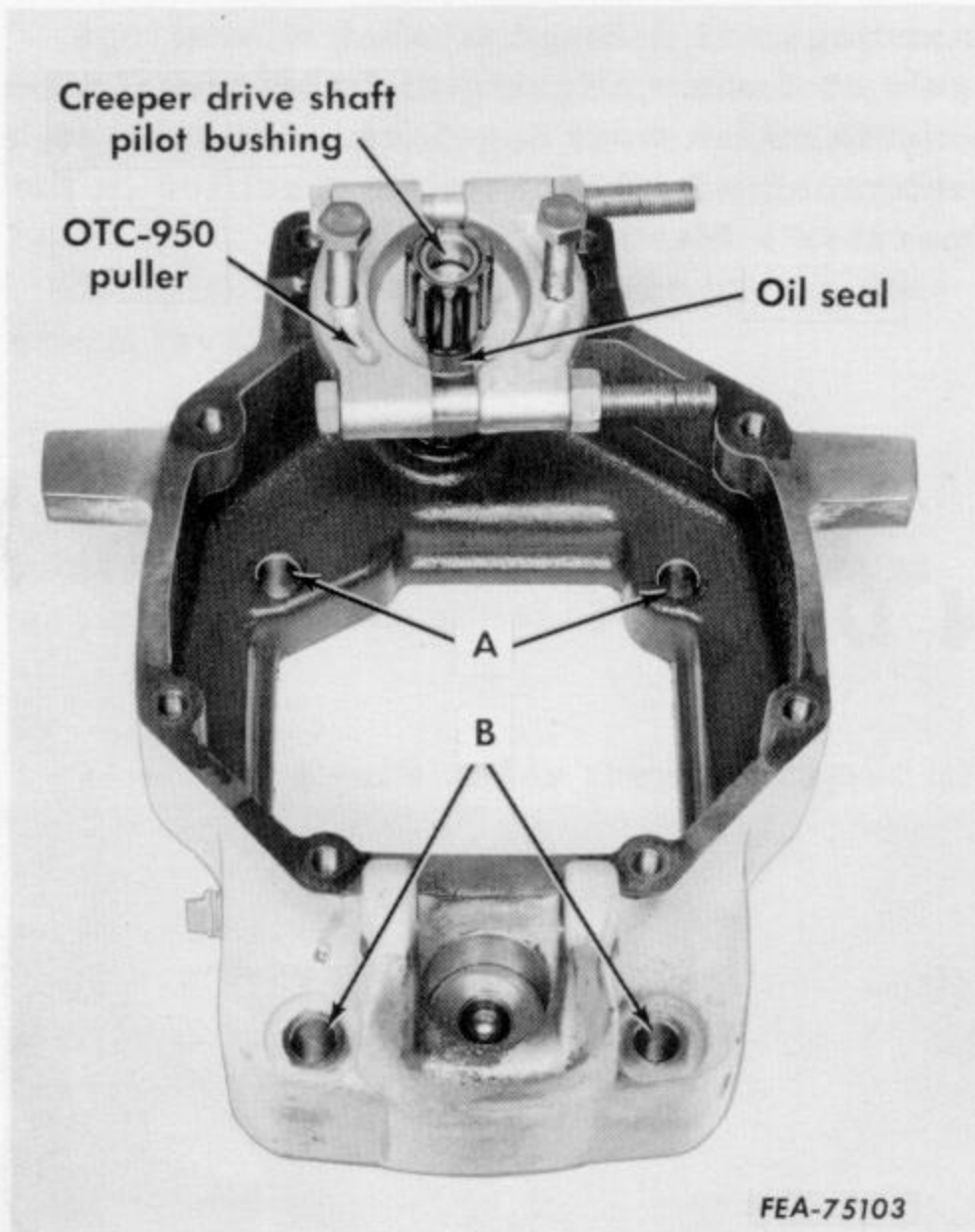

Illust. 22. Pulling reduction drive shaft, seal and bearing.

NOTE: Soft copper sealing washers are used under the "B" capscrew heads.

8. Move the housing forward and away from the transmission housing as the brake disk slides off the transmission countershaft.

9. Pull the reduction drive shaft, seal and bearing from the reduction housing if it was not removed in step 6 **NOTE**.

10. Support the drive shaft splined coupling and drive out the coiled spring pin.

NOTE: The splined coupling is used only on tractors equipped with creeper attachment.

11. Press the drive shaft from the ball bearing.

12. Press the needle bearing rearward from the housing.

13. Remove the brake components.

Inspection and Repair

1. Inspect the drive shaft for wear on the gear teeth, needle bearing area, oil seal contact area and drive pin hole.

2. Inspect the reduction gear teeth for wear or chipping and the fit of the gear on the transmission shaft.

3. On tractors with creeper, inspect wear of pilot bushing for creeper drive shaft.

4. Inspect needle and ball bearings for wear, pitting and roughness of operation.

5. Thoroughly clean the reduction housing.

Reassembly and Installation

1. Install a new gasket to the front of the transmission case. Dowels in the case will hold the gasket in place.

2. Press the needle bearing into the reduction housing from the rear. Rear end of bearing should be flush with housing. Refer to Illust. 3.

3. Press the ball bearing onto the drive shaft. Refer to Illust. 3.

4. Lubricate the lip of a new oil seal and install the seal onto the shaft. Be careful when sliding the seal lip over the pin hole in the shaft. Flat face of seal case must be forward. Refer to Illust. 3 for arrangement of parts.

5. Install the splined coupling and coiled pin (if tractor is equipped with a creeper). Coiled pin ends must be even with or below the spline root to avoid interference when shifting the creeper unit.

6. Install a new O-ring onto the brake lining retainer and install in the reduction housing.

7. Install the reduction housing to the transmission case. Be sure the gasket and dowels are in place.

8. Install new copper sealing washers on the two lower capscrews. Refer to "B" (Illust. 22). Tighten capscrews at "A" and "B" to 80 ft. lbs.

9. Install the brake linings and disk then push the front lining retainer rearward to hold disk and linings in place.

10. Install the reduction gear and spacer to the transmission mainshaft and secure with the capscrew, flat and lockwasher. Tighten capscrew after drive shaft is installed.

11. Install the drive shaft with ball bearing, seal and splined coupling (on tractors with creeper). Seal case should be flush with housing.

NOTE: Seal holds ball bearing in place and front cover holds seal in place.

12. Tighten reduction gear retaining capscrew to 55 ft. lbs.

13. Install new gasket and housing front cover.

14. Install new gasket and creeper unit (on tractors so equipped).

15. Replace the brake push rod, ball, lever and pivot pin.

16. Recouple the tractor by reversing the splitting procedure.

17. Fill transmission and creeper to proper level with specified lubricant.

REAR AXLES

Removal

1. Drain the transmission lubricant.

2. Stabilize the tractor by driving wooden wedges between the front axle and frame on each side and block the front wheels. Refer to Illust. 17.

3. Remove the drawbar and differential housing rear cover.

4. Place a jack under either rear axle carrier and raise the rear wheel off the floor. Remove the "C" type snap ring from the axle shaft inner end. Refer to Illust. 23.

5. Slide the axle out of the differential side gear and axle carrier. Refer to Illust. 24.

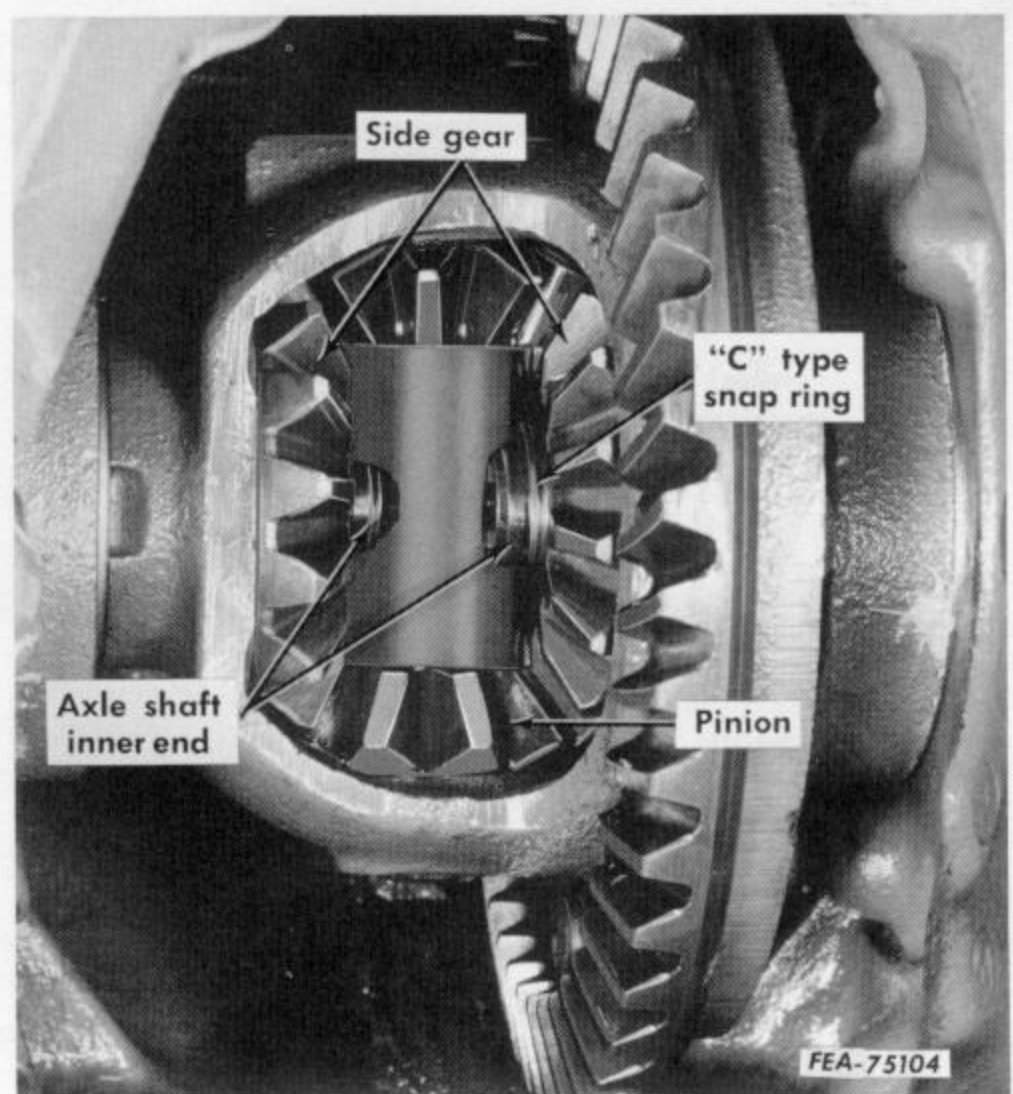

Illust. 23. Differential and rear axle assembly.

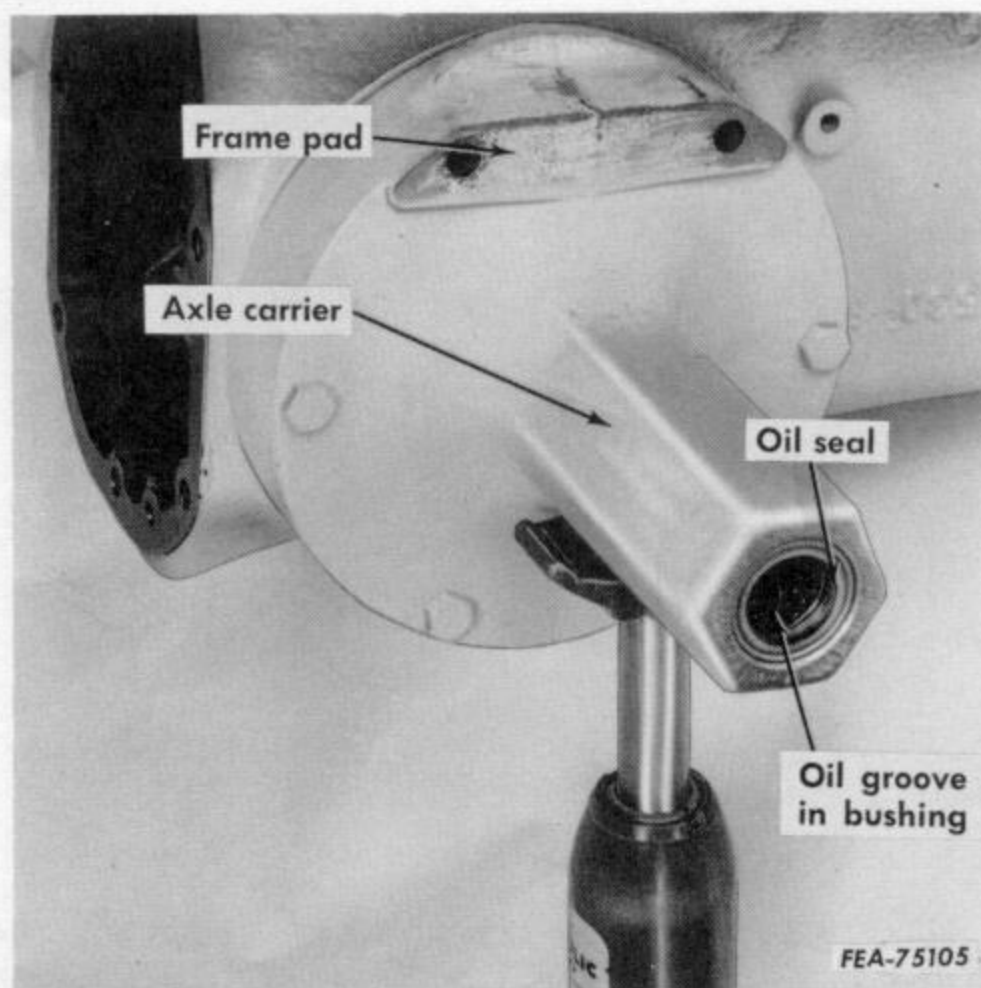

Illust. 24. Rear axle removed.

6. Support the transmission - differential housing on a block and remove the axle carrier. Refer to Illust. 25.

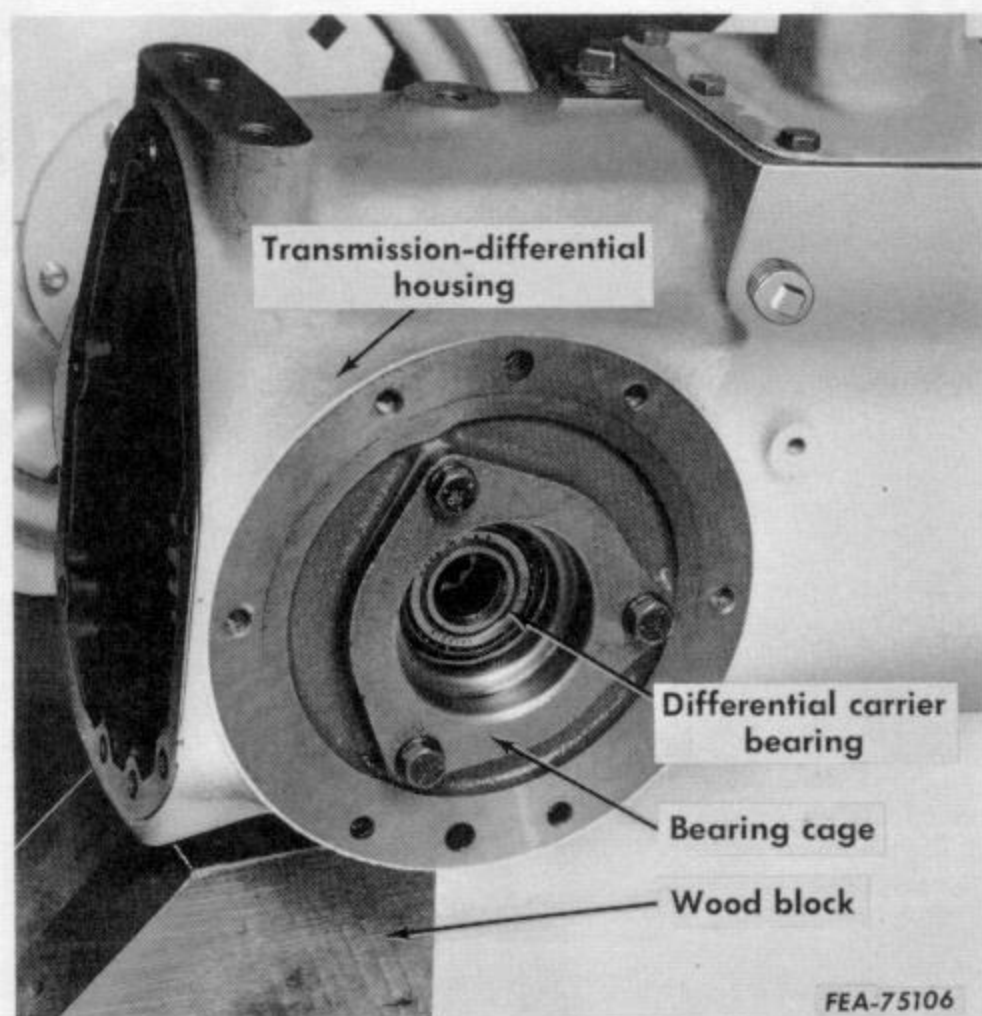

Illust. 25. Rear axle carrier removed.

7. Press the carrier bushing from the carrier.

8. Drive the oil seal from the carrier.

9. Clean the gasket surface of the axle carrier and differential housing.

Inspection

1. Inspect the axle shaft for wear at the oil seal area, bushing location and splines on the inner end.

2. Roll the axle shaft along a flat surface to detect any warping or bending.

3. Check the axle carriers for cracks or breaks. Remove any high spots from the gasket surface with a flat file.

Reassembly

1. Press a new bushing into the axle carrier. The oil groove must be at the bottom.

2. Press a new oil seal into the axle carrier.

3. Using a new gasket, install the axle carrier to the differential housing. Cap-screw threads should be coated with a non-hardening sealer (permatex) to avoid oil leaks. The frame pad of the axle carrier must be to the top as shown in Illust. 24.

4. Fill the cavity between the lips of the oil seal with chassis lube or heavy oil.

5. Lubricate the axle shaft and bushing then slide the shaft through the seal, bushing, carrier and differential side gear. Rotate the axle as it is pushed through to avoid damage to the seal. Wipe off excess lubricant.

6. Install a new "C" type snap ring to the inner end of the axle shaft.

7. Replace the rear cover and drawbar.

8. Fill differential housing to proper level with specified lubricant.

TRANSMISSION AND DIFFERENTIAL

Complete service of the transmission requires splitting of the tractor, removal of the reduction drive (and creeper if so equipped), rear axles, carriers and the differential. The differential can be removed and replaced without disassembling the transmission, however, the transmission countershaft should be removed when checking preload of the differential carrier bearings. The transmission and differential are therefore covered together.

Removal and Disassembly (Differential)

1. Drain the lubricant.
2. Split the tractor. (Refer to page 19.)
3. Remove the reduction drive. (Refer to page 21.)
4. Remove the rear axles and their carriers. (Refer to page 23.)
5. Remove the differential carrier bearing cage and shims from each side. Keep the shims with each cage and identified for each side.
6. Remove the differential from the transmission case.

NOTE: The differential must be turned into position shown in Illust. 26 before it can be removed.

7. Drive out the pinion shaft lock pin.
8. Remove the pinion shaft.
9. Remove the pinion gears and side gears.
10. If the differential drive gear requires separate replacement, press out the eight retaining rivets.



Illust. 26. Removing differential from the transmission case.

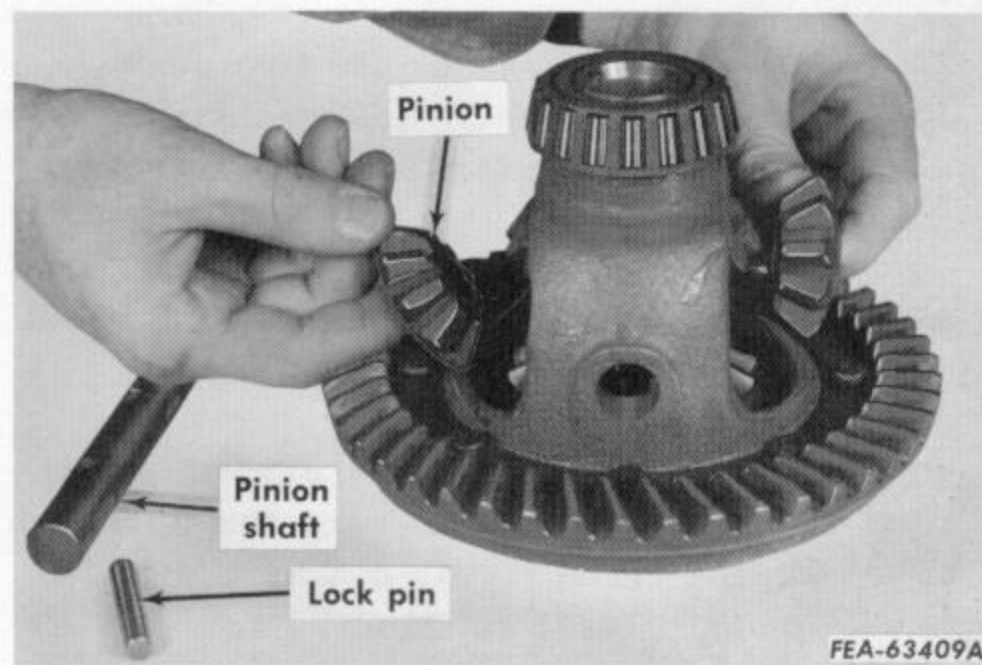

Illust. 27. Differential partially disassembled.

11. Remove the bearing cones from the differential carrier if they are to be replaced.
12. Remove the bearing cups from each cage if replacement is necessary.

Disassembly (Transmission)

1. Remove the differential as previously described on page 25.
2. Remove the gearshift lever and cover assembly.

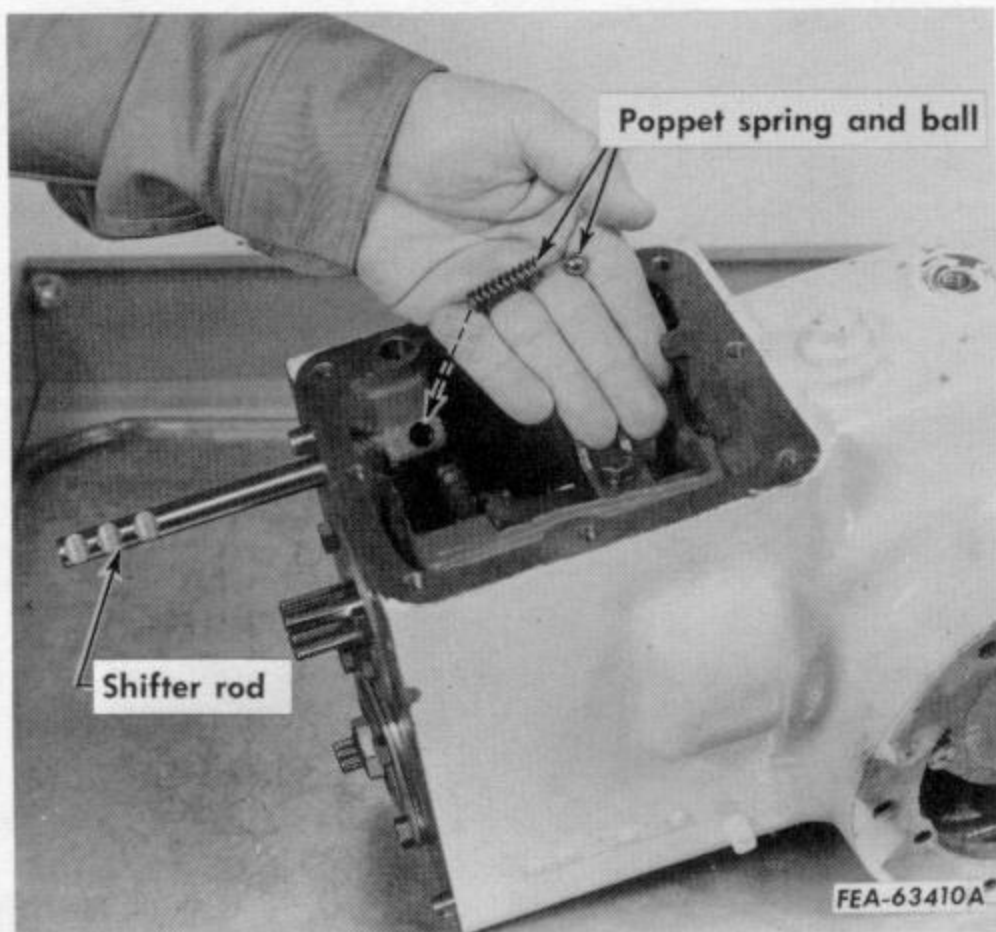

Illust. 28. Removing shifter rods.

Shift the transmission into two gear speeds to lock the transmission then remove the nut from the countershaft.

3. Remove the shifter fork set screws then drive the shifter rods forward and out of the transmission.



CAUTION: Cover the gearshift poppet ball hole to prevent the ball and spring from flying out as the rods are removed. Refer to Illust. 28.

4. Remove the capscrews from the mainshaft front bearing retainer. Refer to Illust. 29.

5. Pull the mainshaft forward and out of the transmission as the gears are removed.

6. Push the countershaft rearward and out of the transmission as the gears and

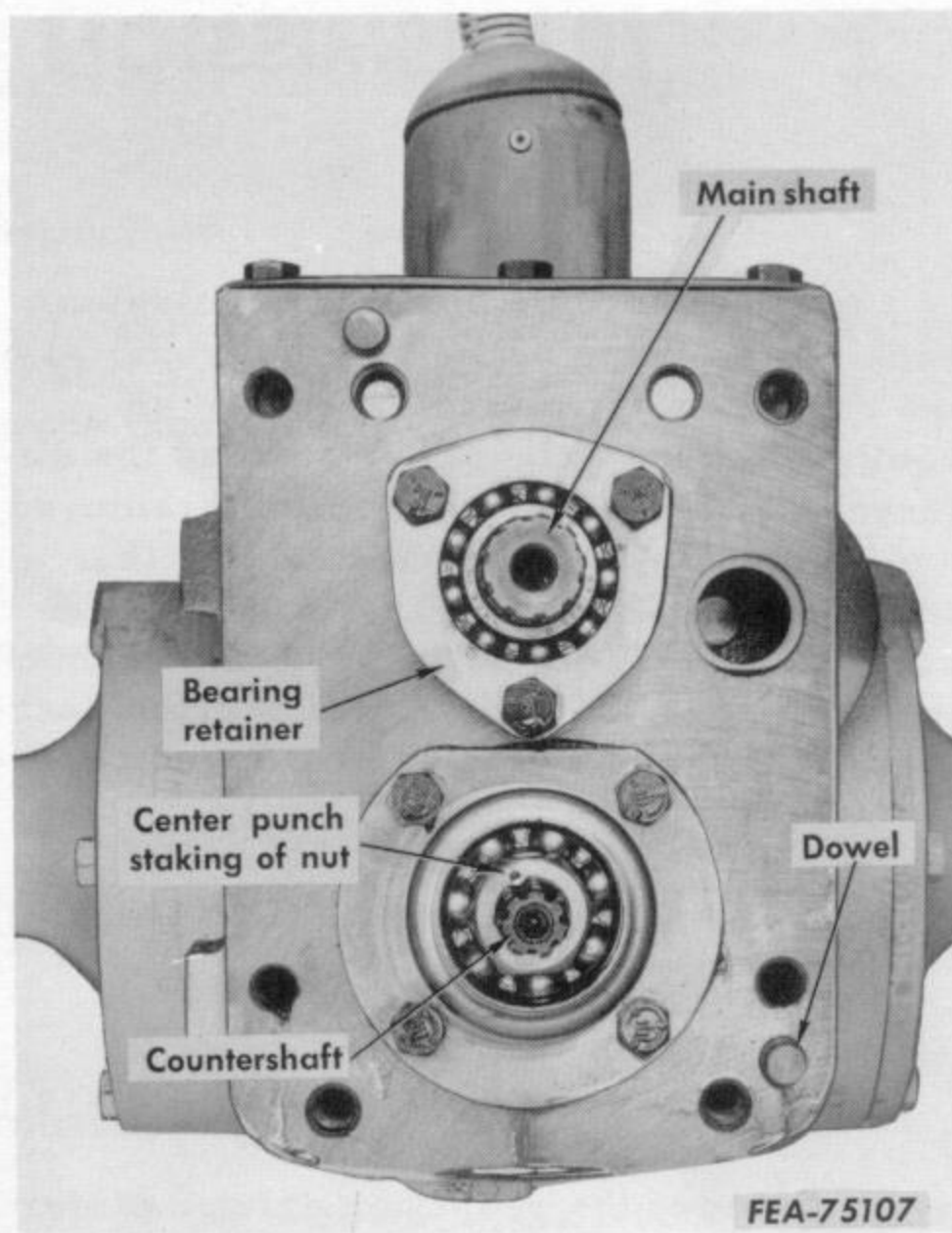

Illust. 29. Front view of transmission.

spacers are removed. Note the sequence of spacers and gears for reassembly. See Specifications for spacer lengths.

7. Pull the mainshaft needle bearing from the housing.
8. Remove the reverse idler shaft and gear.
9. Remove the countershaft front bearing, retainer and shims.

Inspection and Repair

1. Wash all parts in cleaning solvent and dry with compressed air. Do not spin bearings.
2. Check all bearings for looseness, wear, roughness, pitting and scoring.
3. Check gears and shafts for wear and burrs. Remove any burrs with a fine stone.

4. Inspect the housing for cracks, restricted oil passages and dents or raised places on its machine faces. Smooth off raised places with a file.

Reassembly

Reassembly is basically the reverse of disassembly; however, particular attention should be given to the following steps. Refer to Illust. 3 for location of parts.

1. Be sure all bearings are thoroughly lubricated.

2. The transmission mainshaft needle bearing must be installed with its oil hole aligned with the oil hole in the housing.

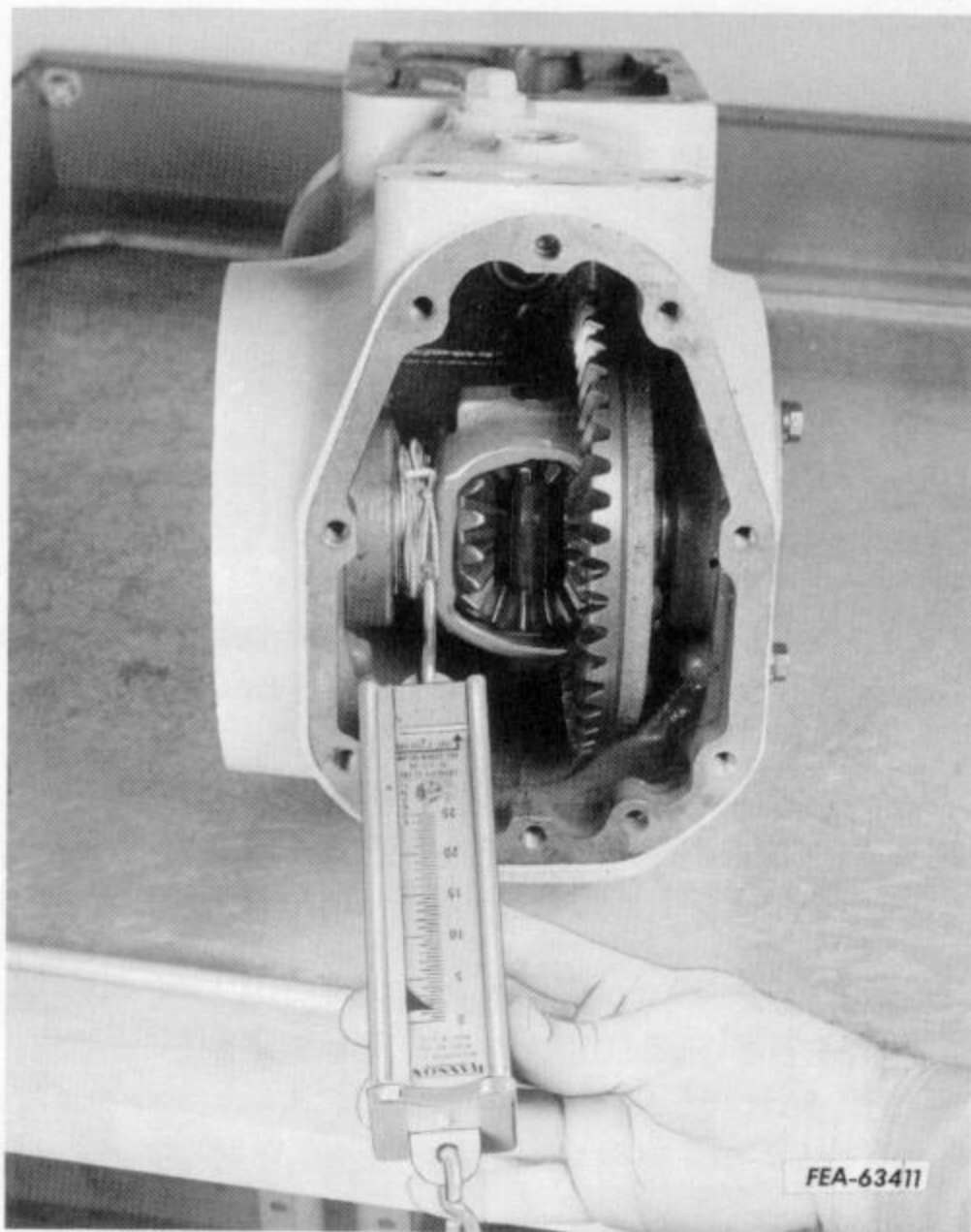

Illust. 30. Checking pre-load of differential bearings.

3. Assemble the differential, carrier bearings, cages and shims. Check bearing pre-load and adjust as necessary before replacing the transmission countershaft. Install or remove shims as necessary. Pre-load is correct when a steady pull of one to

three pounds is necessary to rotate the differential assembly as shown in Illust. 30.

4. Remove the differential assembly, keep the shims with the cages then install the transmission countershaft, bearings, gears, spacers, front bearing retainer, shims and nut. Tighten the nut to 85 ft. lbs. Tighten retainer capscrews to 20 ft. lbs.

5. Install the differential assembly, keeping the pre-load shim pack correct as previously established. Drive gear must be on the right with teeth facing left.

6. Check the backlash between the drive gear and pinion and the gear teeth bearing pattern as follows. Refer to Illust. 31.

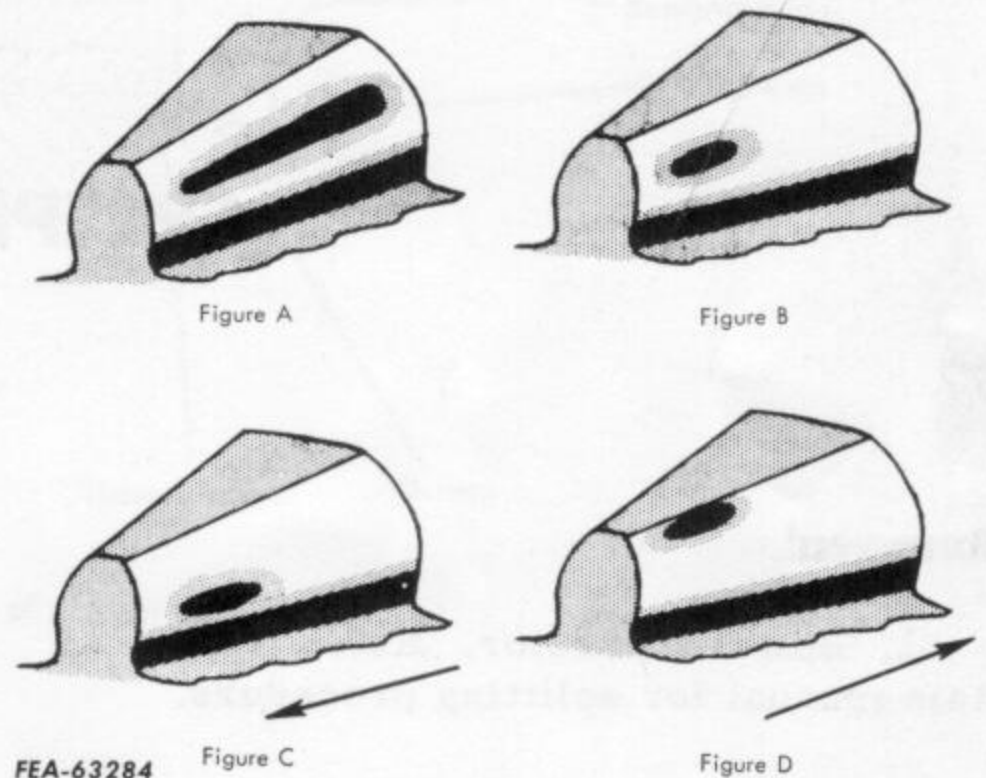

Illust. 31. Tooth bearing pattern.

7. Apply a thin coat of red lead or prussian blue to the bevel pinion teeth faces, then rotate the gears by hand and observe the bearing pattern.

Some deflection will occur under load. Allowance is made in gear design to prevent concentration of load on teeth edges.

8. Hand testing and very light loads should provide a pattern as shown in Figure "B" Illust. 31. When load and deflection increases the pattern will progress as in Figure "A".

9. The desirable (no load) pattern in Figure "B" is the result of adjusting the bevel gear lateral position to the specified range of .003" to .005" backlash.

10. Tooth bearing position from the root to the crown of the tooth is controlled by lateral position of the pinion. If low tooth bearing on bevel pinion is indicated (as shown in Figure "C") the pinion must be adjusted toward the bevel gear. If high tooth bearing on the bevel pinion is indicated (as shown in Figure "D") the pinion must be adjusted away from the bevel gear.

NOTE: If it is necessary to move the pinion in or out to correct "Root-to-crown"

bearing, the bevel gear must also be moved laterally to maintain the specified backlash.

11. Stake the countershaft nut by center-punching the face of the nut over a spline groove. Refer to Illust. 29.

12. Continue the assembly in reverse order of disassembly.

13. Fill housing to proper level with specified lubricant.

NOTE: Creeper attachment has its own lubricant separate of the transmission. Fill creeper at breather and check at side plug in creeper housing.

CREEPER DRIVE

Removal

1. Split the tractor. Refer to page 19 this manual for splitting procedure.

2. Support the transmission and reduction housing on a suitable block, place an oil drip pan under the creeper unit and drain the creeper lubricant. Refer to Illust. 19.

3. Four capscrews hold the creeper housing to the reduction housing cover plate. Remove the capscrews.

4. Bump the creeper to the side to loosen the housing from its gasket and dowels. Pull the creeper forward from the reduction cover and splined coupling.

5. If the driven coupling or the pilot bushing needs replacing, support the coupling and drive out the coiled spring pin. Remove the coupling.

Disassembly

1. Remove the snap ring which holds the input shaft bearing cage in the housing.

2. Pull the shaft, bearing, retainer, planetary assembly and the direct drive coupling from the housing.

NOTE: The spline grooves of the direct drive coupling must align with the splines of the shifter collar.

3. Support the direct drive coupling and drive the coiled spring pin out. Remove the coupling from the shaft.

4. Slide the planet carrier off the input shaft and the planet gears off the carrier pins.

5. Remove the flat thrust washer.

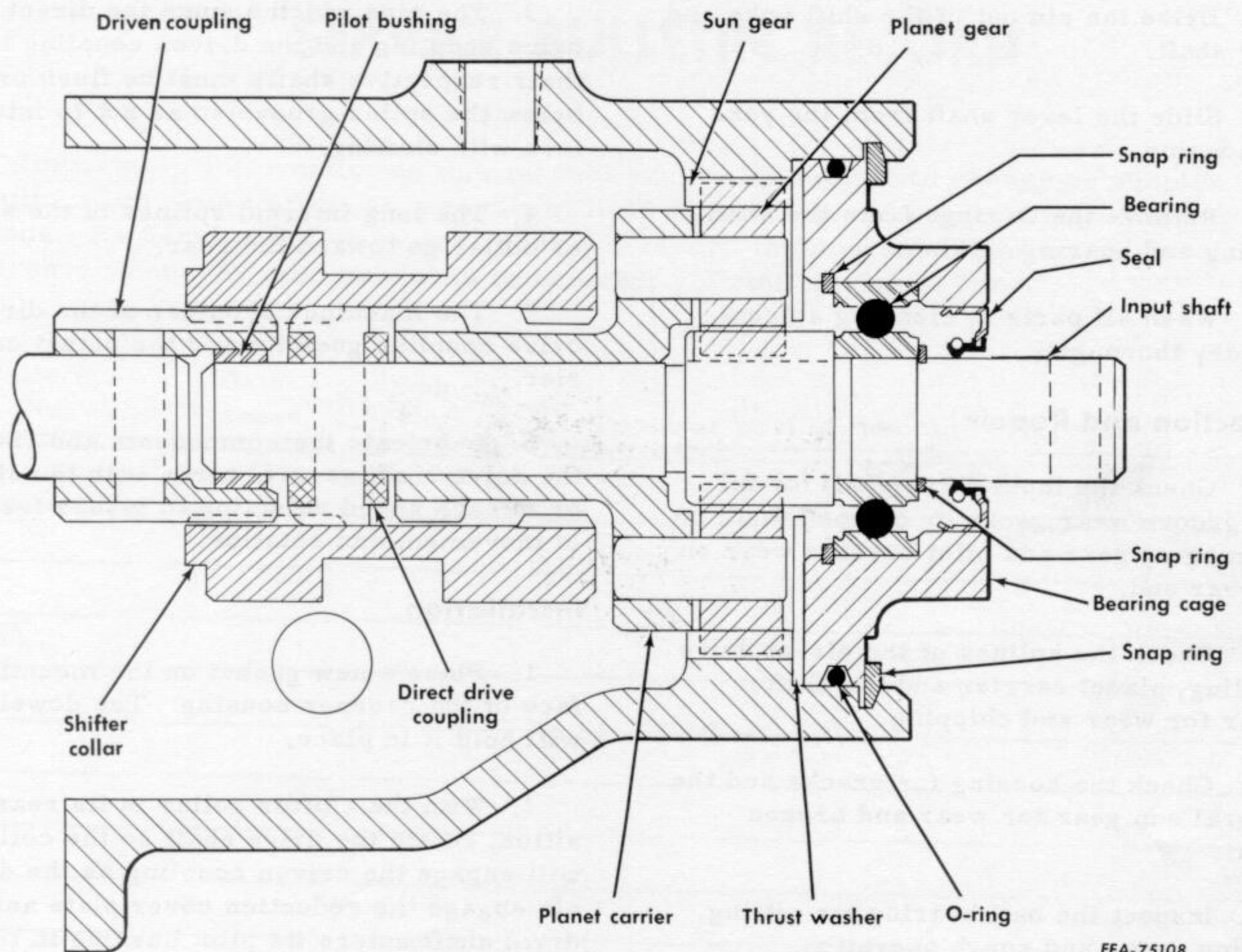

FEA-75108

Illust. 32. Cross section - side view of creeper drive assembly.

6. A snap ring holds the ball bearing outer race in the retainer. Remove the snap ring then push the bearing and shaft from the retainer.

7. The ball bearing is held on the shaft by a snap ring. Remove the snap ring. The shaft can now be pressed from the bearing.

8. Press the oil seal from the bearing retainer.

9. Drive the shift poppet pin from the shaft and remove the poppet.

10. Shift the lever and shifter collar toward the rear of the case and at the same time lift the shifter collar up to disengage it from the shift yoke.

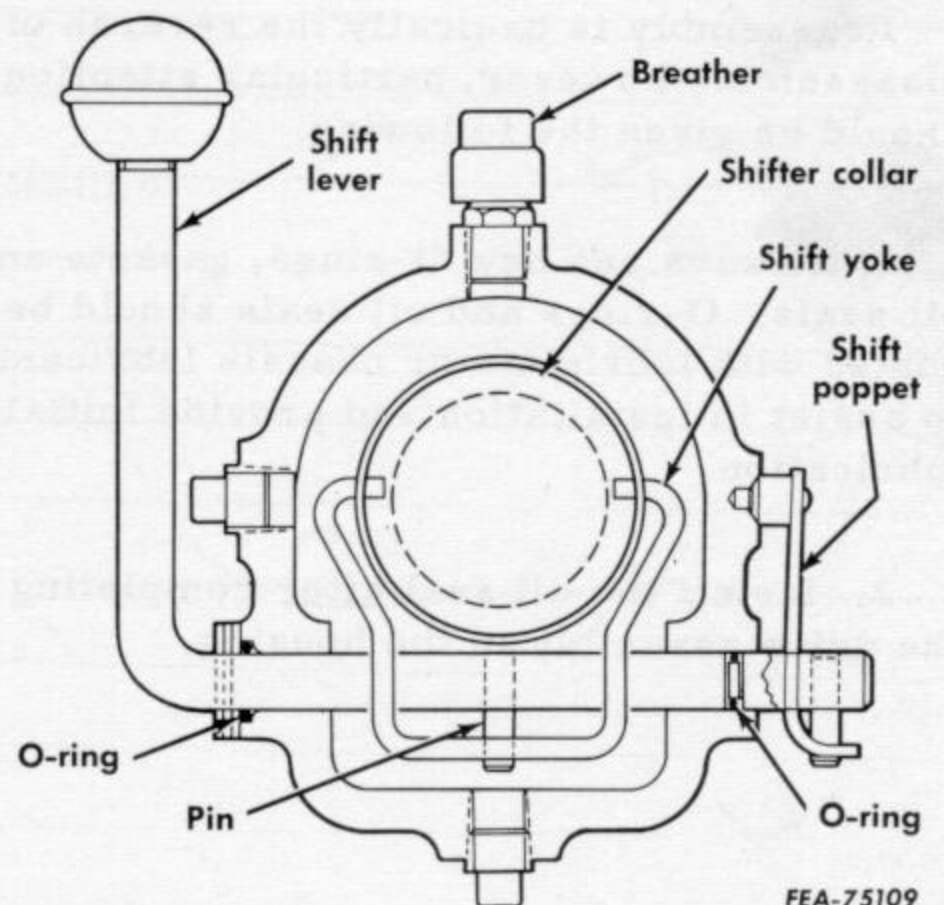

FEA-75109

Illust. 33. Cross section - end view of creeper shifting components.

11. Drive the pin out of the shift yoke and lever shaft.

12. Slide the lever shaft from the yoke and housing.

13. Remove the O-rings from the shaft, housing and bearing retainer.

14. Wash all parts in cleaning solvent then dry thoroughly.

Inspection and Repair

1. Check the input drive shaft for oil seal groove wear, worn or chipped teeth on the integral gear and pilot bushing wear on the rear end.

2. Check the splines of the direct drive coupling, planet carrier and the shifter collar for wear and chipping.

3. Check the housing for cracks and the integral sun gear for wear and broken teeth.

4. Inspect the ball bearing for pitting, scoring, wear and rough operation.

Reassembly

Reassembly is basically the reverse of disassembly however, particular attention should be given the following:

1. Always use new O-rings, gaskets and oil seals. O-rings and oil seals should be coated with lubricate or chassis lubricant to assist in installation and provide initial lubrication.

2. Install the oil seal after completing the drive assembly in the housing.

3. The pins which secure the direct drive coupling and the driven coupling to their respective shafts must be flush or below the spline groove so as not to interfere with shifting.

4. The long internal splines of the shifter collar go toward the rear.

5. The machined shoulder of the direct drive coupling goes toward the planet carrier.

6. Lubricate the components and rotate the drive shaft several turns with the shifter in each speed selection to insure freedom of movement and rotation.

Installation

1. Place a new gasket on the mounting face of the creeper housing. The dowels will hold it in place.

2. With the shifter collar in its rear position, rotate the drive shaft so the collar will engage the driven coupling as the dowels engage the reduction cover plate and the drive shaft enters its pilot bushing in the driven coupling.

3. Secure the creeper to the reduction housing cover plate.

4. Fill the creeper housing to proper level (check plug on side of housing) with the same lubricant as specified for the transmission - differential. Hy-tran fluid or SAE 30 Engine oil.

5. Shift the unit several times to insure freedom of movement. Leave the shifter lever in its forward position for re-coupling the split tractor.

6. Reassemble the split tractor.

Information in this section is subject to change without notice. It is the responsibility of the user to verify the accuracy of the information contained herein. The user should consult the appropriate service manual for the latest information.



1st in service

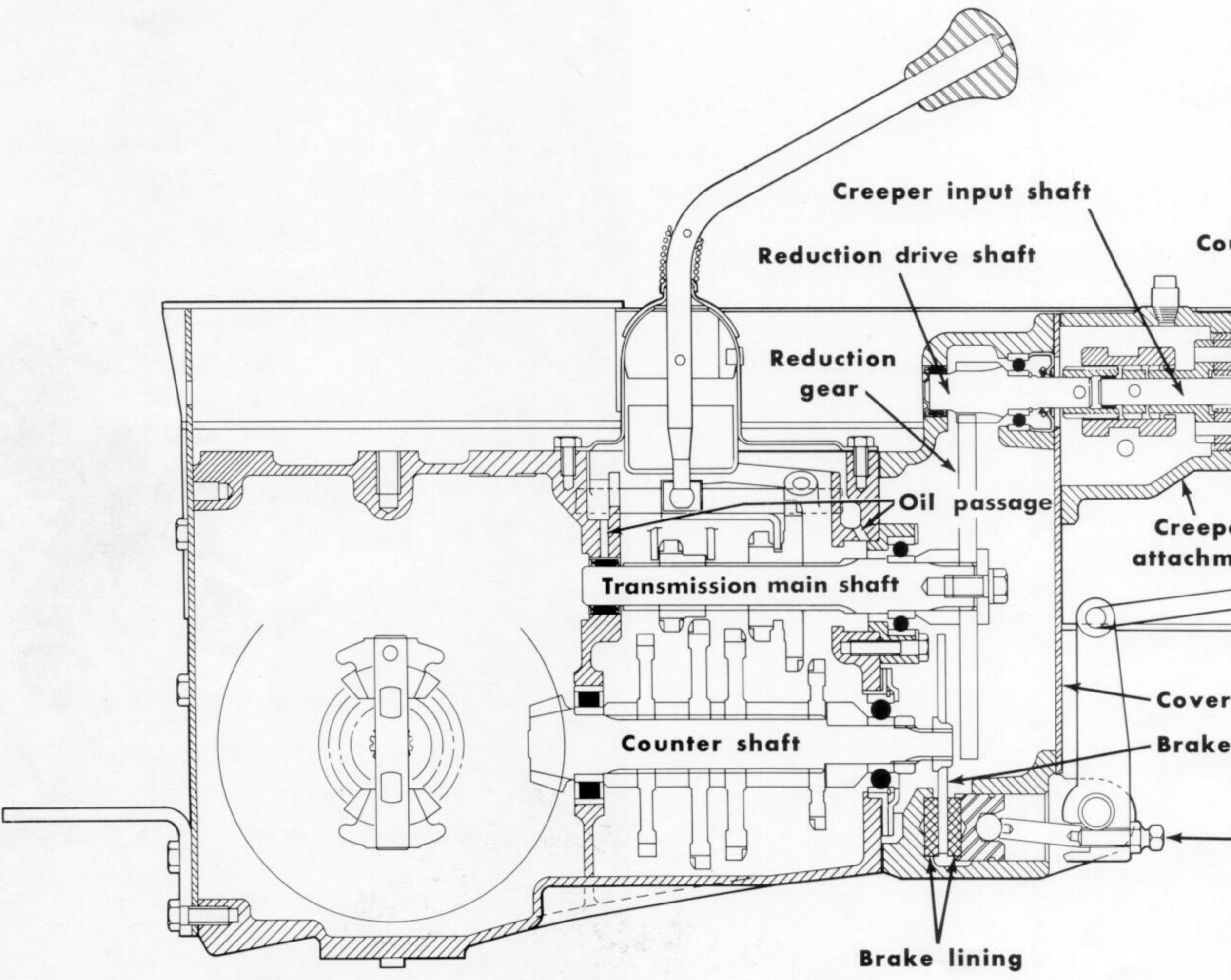

Illust. 3. Cross section - power train.

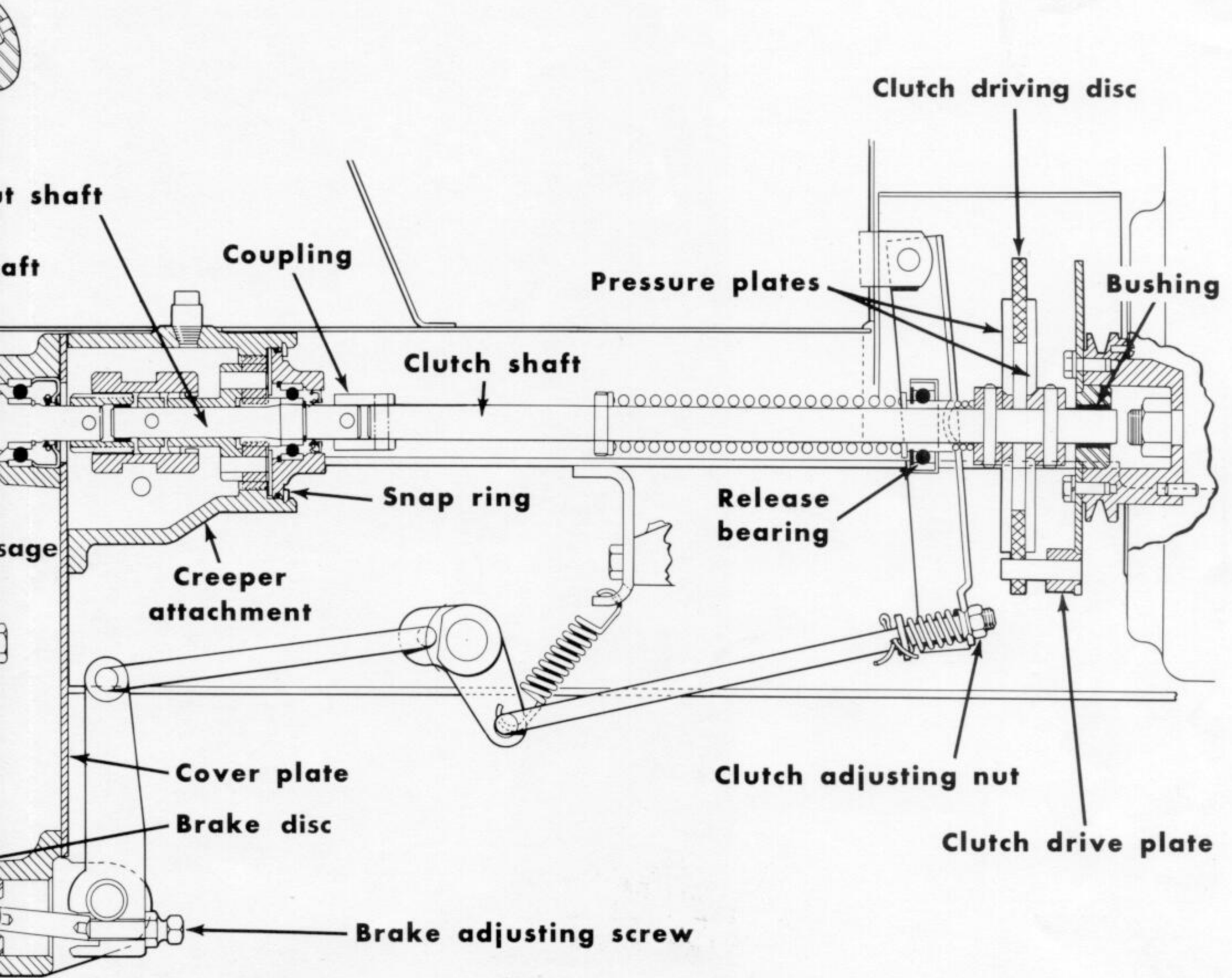

FEB-14034

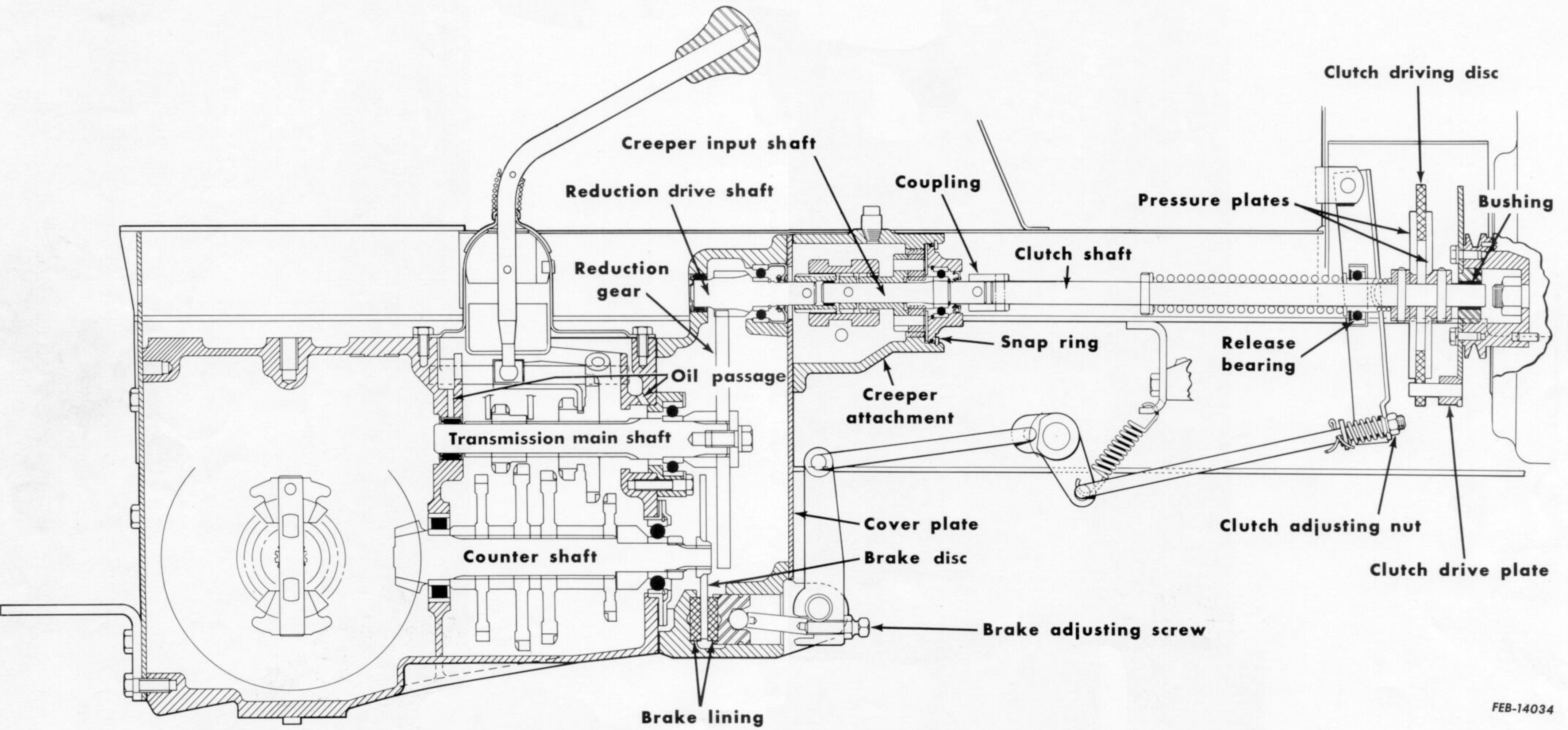

Illust. 3. Cross section - power train.